

# New Zealand Gazette

WELLINGTON: THURSDAY, 21 FEBRUARY 2008

## CONTENTS

### COMMERCIAL

Bankruptcy Notices .....	680
<b>Company Notices —</b>	
Appointment and Release of Receivers / Managers .....	681
Appointment and Release of Liquidators .....	682
Appointment and Release of Administrators .....	693
Meetings and Last Dates by Which to Prove Debts or Claims .....	None
Removals .....	693
Cessation of Business in New Zealand .....	698
Applications for Winding Up / Liquidations .....	698
Partnership Notices .....	706
Other .....	706
<b>Land Transfer / Joint Family Homes Notices .....</b>	<b>707</b>

<b>Charitable Trusts Notices .....</b>	<b>None</b>
<b>Friendly Societies and Credit Unions Notices .....</b>	<b>None</b>
<b>Incorporated Societies Notices .....</b>	<b>None</b>
<b>General Notices .....</b>	<b>708</b>

### GOVERNMENT

<b>Vice Regal .....</b>	<b>None</b>
<b>Parliamentary Notices .....</b>	<b>None</b>
<b>Departmental Notices .....</b>	<b>709</b>
<b>Authorities and Other Agencies of State Notices .....</b>	<b>720</b>
<b>Land Notices .....</b>	<b>721</b>
<b>Regulation Summary .....</b>	<b>726</b>
<b>General Section .....</b>	<b>727</b>
<b>Deadlines .....</b>	<b>729</b>
<b>Index .....</b>	<b>729</b>

## USING THE GAZETTE

The *New Zealand Gazette*, the official newspaper of the Government of New Zealand, is published weekly on Thursday. Publishing time is 4.00pm.

**Closing time for lodgement of notices under the Companies, Partnership, Insolvency and Land Transfer Acts is 12.00 midday on Monday** (except where that day is a public holiday, in which case the deadline will be 12.00 midday on the last working day of the preceding week).

**All other notices must be lodged at the *New Zealand Gazette* office by 12.00 midday, Tuesday, in the week of publication.**

Notices are accepted for publication in the next available issue, unless otherwise specified.

Notices may be submitted by email, facsimile or post. Dates and proper names should be shown clearly.

A covering instruction setting out requirements should accompany all notices, but the *New Zealand Gazette* reserves the right to apply its in-house style.

Notices for publication and related correspondence should be addressed to

New Zealand Gazette  
Department of Internal Affairs  
PO Box 805  
Wellington  
Telephone: (04) 470 2930 / (04) 470 2931  
Facsimile: (04) 470 2932  
Email: [gazette@parliament.govt.nz](mailto:gazette@parliament.govt.nz)



**Cancelled Notices**

Notices cancelled after being accepted for publication will be subject to a charge of \$55.00 to cover setting up and deleting costs. The deadline for cancelling notices is 12.00 midday on Wednesdays.

**Advertising Rates**

The following rate applies for the insertion of all notices in the *New Zealand Gazette*: 50c per word/number.

Customers will be invoiced in accordance with standard commercial practices.

Advertising rates are not negotiable.

All rates shown are inclusive of GST.

**Other editions of the *New Zealand Gazette***

*Customs Edition* – Published weekly on Tuesday.

*Special Editions, Professional & Trade Lists and Supplements* – Published as and when required.

**Availability**

*New Zealand Gazette* editions and a search-by-notice facility are available on the website

[www.gazette.govt.nz](http://www.gazette.govt.nz)

All editions are also available on subscription from the New Zealand Gazette Office, Department of Internal Affairs, PO Box 805, Wellington (telephone: (04) 470 2930), or over the counter at

Bennetts Government Bookshop, Bowen House, Lambton Quay, Wellington.

**Copyright**

© The *New Zealand Gazette* is subject to Crown copyright.

For more information visit

[www.gazette.govt.nz](http://www.gazette.govt.nz)

---

## Bankruptcy Notices

---

**Bankruptcies**

The official assignee advises the following bankruptcies:

**Adams, Gillian** (also known as **Deller, Gillian** and **Mellish, Gillian**), 34 Iorns Street, Masterton – 12 February 2008.

**Aloese, Eseta**, 47 Kelman Road, Kelston, Auckland – 7 February 2008.

**Aloua, Viliami**, 248 Matapihi Road, RD 5, Tauranga – 11 February 2008.

**Anderson, Shane**, Tauranga – 11 February 2008.

**Ashley, Kelly**, 10/9 Harrison Road, Eilerslie, Auckland – 12 February 2008.

**Aumatagi, Robert**, 39B Shortland Street, Wainoni, Christchurch – 12 February 2008.

**Browning, David**, 233D Markham Road, RD 3, Drury, Auckland – 8 February 2008.

**Byrnes, Dominic**, Wellington – 12 February 2008.

**Charles, Trish**, 3 Kawatiri Grove, Wainuiomata, Lower Hutt – 12 February 2008.

**Clarke, Angela** (also known as **Heenan, Angela**), 206 Greers Road, Bishopdale, Christchurch – 15 February 2008.

**Clinton, Duane**, 41 Campbell Road, Mt Maunganui, Tauranga – 11 February 2008.

**Cooke, Adrian**, 5 Phillip Street, Putaruru – 11 February 2008.

**Devoe, Peter**, 36B Princes Street, Onehunga, Auckland – 7 February 2008.

**Dowdall, Nicola**, 399 Maunganui Road, Mt Maunganui, Tauranga – 11 February 2008.

**Fitzgerald, Leon**, 2/251 Lincoln Road, Henderson – 13 February 2008.

**Goodchap, Leanne**, 155 Jeffs Road, East Tamaki, Auckland – 13 February 2008.

**Goodley, Heath**, 1/48B Miro Street, Trentham, Upper Hutt – 13 February 2008.

**Gordon, Lance**, 12/57 Wolverton Street, Avondale, Auckland – 13 February 2008.

**Harding, Desna** (also known as **Orchard, Desna**), Unit 5, 68 Turner Drive, Pleasant Heights, Rotorua – 13 February 2008.

**Harimate, Derek**, Auckland – 12 February 2008.

**Harris, Leticia**, 84 Clyde Street, Tokoroa – 14 February 2008.

**Hemara, Brian**, 35 York Street, Rotorua – 11 February 2008.

**Hettig, Richard**, 233 Whitehills Road, RD 1, Kaukapakapa, Auckland – 7 February 2008.

**Hobcroft, Tristyn**, 14 Garland Road, Ruakaka, Whangarei – 15 February 2008.

**Hollever, Aaron**, 25A Arama Street, Taupo – 11 February 2008.

**Holmes, Richard**, 15A Riverview Road, New Lynn, Auckland – 13 February 2008.

**Hood, Mervyn**, 50 Highridge Road, RD 2, Clevedon, Auckland – 7 February 2008.

**Isley, Alec**, 143 Otonga Road, Rotorua – 11 February 2008.

**Kennedy, Catherine**, 106 Mana Esplanade, Paremata, Porirua, Wellington – 12 February 2008.

**Kent, Tony**, 11 Whangaparaoa Road, Whangaparaoa, Auckland – 7 February 2008.

**Kim, Martin**, 1/1 Long Street, Long Bay, Auckland – 13 February 2008.

**Lester, Richard**, 67 Tuhingamata Road, Taupo – 11 February 2008.

**Liuu, Chi** (also known as **Lim Liuu, Chi Khoun**), 43B Rata Street, New Lynn, Auckland – 13 February 2008.

**Ma, Ying**, 15 Thornbill Rise, The Palms, Auckland – 14 February 2008.

**Maukau, Jason** (also known as **Maukau-Brand, Jason** and **Brand, Jason**), 10 Albert Street, Papakura, Auckland – 13 February 2008.

**Maxwell, Shaun**, 21 Campbell Street, Waiuku, Auckland – 12 February 2008.

**McIntyre, Vicky-Lee**, 9/5 Monte Cassino Place, Birkenhead, Auckland – 13 February 2008.

**McMahon, Ngametua**, 14 Bay Drive, Titahi Bay, Wellington – 8 February 2008.

**Mok, Saron**, 21B Crawford Avenue, Mangere, Auckland – 12 February 2008.

**Ngarongo, Tessa**, 1013A Aparimu Road, RD 3, Drury – 12 February 2008.

**Owen, John**, 14 Hall Road, Ngongataha, Rotorua – 11 February 2008.

**Parata, Anthony**, 35 Manuka Street, Gisborne – 11 February 2008.

**Phommasa, Somsanit**, 42 Milan Drive, Glen Eden, Auckland – 7 February 2008.

**Preston, Francis**, 70 Victoria Avenue, Remuera, Auckland – 7 February 2008.

**Preston, Ian**, 70 Victoria Avenue, Remuera, Auckland – 7 February 2008.

**Pryor, Gordon**, 2 Eastwood Rise, Browns Bay, Auckland – 8 February 2008.

**Quach, Chheng**, 43B Rata Street, New Lynn, Auckland – 7 February 2008.

**Redshaw, Paul**, 642 Oruanui Road, Taupo – 11 February 2008.

**Roeszler, Katie**, 320 Oldfield Road, Waihi – 11 February 2008.

**Scott, Gavin**, 21A Levesque Street, Beach Haven, Auckland – 7 February 2008.

**Scott, Neil**, 4 Cornel Circle, Snells Beach, Auckland – 13 February 2008.

**Somerville, Wayne**, 12 Cambrian Street, Churton Park, Wellington – 11 February 2008.

**Tamale, Fatafehi**, 21/21 Melton Road, Sylvia Park, Auckland – 18 February 2008.

**Taylor, Tessa** (also known as **Ngaheke, Tessa**), 25 Hedley Place, Raumanga, Whangarei – 14 February 2008.

**Thompson, Gordon**, 79 Victory Road, Laingholm, Auckland – 12 February 2008.

**Tumai, Miles**, 4/760 Remuera Road, Remuera, Auckland – 12 February 2008.

**Vivditch, Peter**, 48 Rising Parade, Albany, Auckland – 13 February 2008.

**Webster, Nick**, 4 Palliser Place, Mt Maunganui, Tauranga – 11 February 2008.

**Winterbottom, Martyn**, 13C Walbrook Road, Manly, Auckland – 7 February 2008.

OFFICIAL ASSIGNEE.

Private Bag 4714, Christchurch. Freephone: 0508 467 658.  
Website: [www.insolvency.govt.nz](http://www.insolvency.govt.nz)

ba1161

### No Asset Procedures

The official assignee advises the following no asset procedures:

**Gower, Amanda**, Manuka Road, Glenfield, North Shore, Auckland – 13 February 2008.

**Maaka, Keri**, 102 Clonbern Road, Remuera, Auckland – 14 February 2008.

**Maguigan, Craig**, 37 Forest Street, Tapanui – 14 February 2008.

**Mence, Kelly-Jayne**, 36 Worcester Street, West End, Palmerston North – 12 February 2008.

**Taylor, Louise**, 11 Lichfield Crescent, Tamatea, Napier – 12 February 2008.

OFFICIAL ASSIGNEE.

Private Bag 4714, Christchurch. Freephone: 0508 467 658.  
Website: [www.insolvency.govt.nz](http://www.insolvency.govt.nz)

ba1160

### In Bankruptcy

#### Notice of Order Annuling an Adjudication

The order of adjudication dated 4 July 2007 against **Hamilton, Nigel Douglas**, 65 West Harbour Drive, West Harbour, Auckland, was annulled by order of the High Court at Auckland, pursuant to section 119(1)(b) of the Insolvency Act 1967, with effect from 10 October 2007.

OFFICIAL ASSIGNEE.

Insolvency and Trustee Service, Private Bag 4714, Christchurch. Freephone: 0508 467 658. Website: [www.insolvency.govt.nz](http://www.insolvency.govt.nz)

ba1173

## Company Notices

### APPOINTMENT AND RELEASE OF RECEIVERS / MANAGERS

#### Cowperthwaite Limited (in receivership)

##### Notice of Appointment of Receivers and Managers

*Pursuant to Section 8(1)(b) of the Receiverships Act 1993*

Notice is hereby given that on 7 February 2008, Anthony John McCullagh, chartered accountant, and Stephen Mark Lawrence, insolvency practitioner, both of Auckland, were appointed jointly and severally as receivers and managers of Cowperthwaite Limited under the terms of a general security agreement dated the 4th day of August 2004.

*The Property in Receivership is:* All present and after acquired personal property of the company.

*Office Addresses of the Receivers and Managers:* Horwath Corporate (Auckland) Limited, Level 3, 48 Courthouse Lane, Chancery, Auckland 1010. *Postal Address:* PO Box 3678, Auckland 1140. *Telephone:* (09) 302 0521. *Facsimile:* (09) 302 0536. *Email:* [horcorp@horwath.co.nz](mailto:horcorp@horwath.co.nz)

Dated this 7th day of February 2008.

STEPHEN MARK LAWRENCE, Receiver and Manager.

ar971

#### International Environmental Engineering Limited (in receivership)

##### Notice of Appointment of Receivers and Managers

*Pursuant to Section 8(1)(b) of the Receiverships Act 1993*

Notice is hereby given that on 15 February 2008, Anthony John McCullagh, chartered accountant, and Stephen Mark Lawrence, insolvency practitioner, both of Auckland, were appointed jointly and severally as receivers and managers of International Environmental Engineering Limited under the terms of a general security agreement dated the 9th day of May 2003.

*The Property in Receivership is:* All present and after acquired personal property of the company.

*Office Addresses of the Receivers and Managers:* Horwath Corporate (Auckland) Limited, Level 3, 48 Courthouse Lane, Chancery, Auckland 1010. *Postal Address:* PO Box 3678, Auckland 1140. Telephone: (09) 302 0521. Facsimile: (09) 302 0536. Email: horcorp@horwath.co.nz

Dated this 18th day of February 2008.

STEPHEN MARK LAWRENCE, Receiver and Manager.

ar1158

## APPOINTMENT AND RELEASE OF LIQUIDATORS

### Appointment of Liquidator

The official assignee advises the following liquidations:

5 February 2008

**Casino Park Lodge Motel (1997) Limited.**

8 February 2008

**Executive Publishing Network NZ Limited.**

**Iridescent Design Limited.**

**Margran New Zealand Limited.**

**Tawari Street Trustee Limited.**

14 February 2008

**Point Wines Limited.**

OFFICIAL ASSIGNEE.

Private Bag 4714, Christchurch. Freephone: 0508 467 658. Website: www.insolvency.govt.nz

al1159

**Lift Tranz Limited, Human Commercials Limited, Scorpik Ventures Limited, Artz Hair Limited, CLC Construction Limited and Medictronix New Zealand Limited**

### Notice of Appointment of Liquidators

Kenneth Peter Brown and Robert James Neilson were appointed joint and several liquidators of the companies on the dates and times below:

8 February 2008

**Lift Tranz Limited** at 11.26am.

11 February 2008

**Human Commercials Limited** at 12.31pm.

**Scorpik Ventures Limited** at 12.39pm.

**Artz Hair Limited** at 12.43pm.

**CLC Construction Limited** at 1.00pm.

14 February 2008

**Medictronix New Zealand Limited** at 10.22am.

K. P. BROWN, Joint Liquidator.

*Address of Liquidators:* C/o Rodewald Hart Brown Limited, 127 Durham Street (PO Box 13380), Tauranga. Telephone: (07) 571 6280. Website: www.rhb.co.nz

al1137

**Dave Orrell Builders Limited, Minginui Village Council Limited, Momentum Media Limited and Oceanfront Holdings Limited**

### Notice of Appointment of Liquidators

Kenneth Peter Brown and Thomas Lee Rodewald were appointed joint and several liquidators of the companies on the dates and times below:

11 February 2008

**Dave Orrell Builders Limited** at 12.01pm.

**Minginui Village Council Limited** at 12.16pm.

14 February 2008

**Momentum Media Limited** at 9.00am.

**Oceanfront Holdings Limited** at 9.00am.

K. P. BROWN, Joint Liquidator.

*Address of Liquidators:* C/o Rodewald Hart Brown Limited, 127 Durham Street (PO Box 13380), Tauranga. Telephone: (07) 571 6280. Website: www.rhb.co.nz

al1136

**Master Butchers Marlborough Limited and 1208979 Limited** (both in liquidation)

### Notice of Appointment of Liquidator

Notice is hereby given, pursuant to section 255(2) of the Companies Act 1993, that, by way of entry in the minute books of the above-named companies in accordance with section 122 of the Companies Act 1993, John Michael Gilbert was appointed liquidator of the companies on the dates and times below:

13 February 2008

**Master Butchers Marlborough Limited** (in liquidation) at 3.00pm.

14 February 2008

**1208979 Limited** (in liquidation) at 9.00am.

### Notice to Creditors to Claim

The liquidator does hereby fix 14 March 2008, as the day on or before which the creditors of the companies are to make their claims and to establish any priority their claims may have, under section 312 of the Companies Act 1993, or to be excluded from the benefit of any distribution made before their claims are made or, as the case may be, from objecting to any distribution.

J. M. GILBERT, Liquidator.

*Address of Liquidator:* C/o C & C Strategic Limited, Private Bag 47927, Ponsonby, Auckland. Telephone: (09) 376 7506. Facsimile: (09) 376 6441.

*All Enquiries to:* John Gilbert.

al1099

**Fox & Fox Limited** (in liquidation)

### Notice of Appointment of Liquidators

*Pursuant to Section 241(2)(c) of the Companies Act 1993*

David Stuart Vance and Barry Phillip Jordan, chartered accountants, were appointed liquidators jointly and severally of the company by the High Court at Wellington on the date and time below:

8 February 2008

**Fox & Fox Limited** (in liquidation) at 10.14am.

### Notice to Creditors to Lodge Claims

The liquidators have fixed 14 March 2008, as the last day for creditors to make their claims and establish any priority their claims may have.

Creditors who have not made a claim at the date a distribution is declared will be excluded from the benefit of that distribution and those creditors may not object to that distribution.

### General Notes

Enquiries for information relating to the liquidations may be made to Nick Flack at PPB McCallum Petterson,



Level 8, The Todd Building, 95 Customhouse Quay (PO Box 3156), Wellington. Telephone: (04) 499 7796. Facsimile: (04) 499 7784.

DAVID STUART VANCE, Liquidator.

*Note:* Any creditors claiming a security interest in respect of the above-named company should provide details to the liquidators urgently.

al1979

### **Dream Property Concepts Limited (in liquidation)**

#### **Notice of Appointment of Liquidators**

*Pursuant to Section 241(2)(c) of the Companies Act 1993*

Henry David Levin, insolvency specialist, and David Stuart Vance, chartered accountant, were appointed liquidators jointly and severally of the company by the High Court at Auckland on the date and time below:

14 February 2008

**Dream Property Concepts Limited** (in liquidation) at 10.33am.

#### **Notice to Creditors to Lodge Claims**

The liquidators have fixed 20 March 2008, as the last day for creditors to make their claims and establish any priority their claims may have.

Creditors who have not made a claim at the date a distribution is declared will be excluded from the benefit of that distribution and those creditors may not object to that distribution.

#### *General Notes*

Enquiries for information relating to the liquidation may be made to Monique Nielsen at PPB McCallum Petterson, Level 11, Forsyth Barr Tower, 55–65 Shortland Street, Auckland. *Postal Address:* PO Box 6916, Wellesley Street, Auckland. Telephone: (09) 336 0000. Facsimile: (09) 336 0010.

HENRY DAVID LEVIN, Liquidator.

*Note:* Any creditors claiming a security interest in respect of the above-named company should provide details to the liquidators urgently.

al1090

### **Mainly Chairs Limited, Duct Installation & Services Limited, HFC Limited, Wingsfield Limited, Express Construction Limited, SS Service Centre Limited, MHS New Zealand Limited and Duke Street Discounts Limited (all in liquidation) (“the companies”)**

#### **Notice of Appointment of Liquidators**

Vivian Judith Fatupaito, insolvency practitioner, and Colin Thomas McCloy, chartered accountant, both of Auckland, were appointed by the High Court, pursuant to section 241(2)(c) of the Companies Act 1993 (“the Act”), as joint and several liquidators of the companies on 14 February 2008 at the times stated:

- **Mainly Chairs Limited** at 10.11am.
- **Duct Installation & Services Limited** at 10.14am.
- **HFC Limited** at 10.26am.
- **Wingsfield Limited** at 11.05am.
- **Express Construction Limited** at 11.52am.
- **SS Service Centre Limited** at 12.00 midday.
- **MHS New Zealand Limited** at 12.05pm.
- **Duke Street Discounts Limited** at 12.08pm.

#### **Notice to Creditors to Claim**

Notice is given that as liquidators of the companies, we fix 14 May 2008, as the day on or before which the creditors of

the companies are to make their claims and to establish any priority their claims may have, under section 312 of the Companies Act 1993, or to be excluded from the benefit of any distribution made before the debts are claimed or, as the case may be, from objecting to the distribution.

Dated this 15th day of February 2008.

VIVIAN FATUPAITO, Liquidator.

*Claims Are to be Forwarded and Creditors and Shareholders May Direct Enquiries to:* C/o PricewaterhouseCoopers, 188 Quay Street (Private Bag 92162), Auckland. Telephone: (09) 355 8000. Facsimile: (09) 355 8013.

*Attention:* Jamie Rihia.

al1103

### **Gridline Construction Limited (in liquidation)**

#### **Notice of Appointment of Liquidators**

Vivian Judith Fatupaito, insolvency practitioner, and Colin Thomas McCloy, chartered accountant, both of Auckland, were appointed joint and several liquidators of Gridline Construction Limited by the shareholders, pursuant to section 241(2)(a) of the Companies Act 1993 (“the Act”), on 5 February 2008 at 1.30pm.

#### **Notice to Creditors to Claim**

Notice is given that as liquidators of Gridline Construction Limited, we fix 5 April 2008, as the day on or before which the creditors of the company are to make their claims and to establish any priority their claims may have, under section 312 of the Companies Act 1993, or to be excluded from the benefit of any distribution made before the debts are claimed or, as the case may be, from objecting to the distribution.

Dated this 11th day of February 2008.

VIVIAN FATUPAITO, Liquidator.

*Claims Are to be Forwarded and Creditors and Shareholders May Direct Enquiries to:* Gridline Construction Limited (in liquidation), c/o PricewaterhouseCoopers, 188 Quay Street (Private Bag 92162), Auckland. Telephone: (09) 355 8000. Facsimile: (09) 355 8013.

*Attention:* Janet Sprosen.

al1041

### **Photo Enterprises Limited (in liquidation)**

#### **Notice of Appointment of Liquidators**

Vivian Judith Fatupaito, insolvency practitioner, and Colin Thomas McCloy, chartered accountant, both of Auckland, were appointed joint and several liquidators of Photo Enterprises Limited by the High Court, pursuant to section 241(2)(c) of the Companies Act 1993 (“the Act”), on 11 February 2008 at 12.07pm.

#### **Notice to Creditors to Claim**

Notice is given that as liquidators of Photo Enterprises Limited, we fix 11 May 2008, as the day on or before which the creditors of the company are to make their claims and to establish any priority their claims may have, under section 312 of the Companies Act 1993, or to be excluded from the benefit of any distribution made before the debts are claimed or, as the case may be, from objecting to the distribution.

Dated this 12th day of February 2008.

VIVIAN FATUPAITO, Liquidator.

*Claims Are to be Forwarded and Creditors and Shareholders May Direct Enquiries to:* Photo Enterprises Limited (in liquidation), c/o PricewaterhouseCoopers, 188 Quay

Street (Private Bag 92162), Auckland. Telephone: (09) 355 8000. Facsimile: (09) 355 8013.

Attention: Adrienne Stone.

al1040

**Art Apartments (2006) Limited** (in liquidation), **Art Properties Limited** (in liquidation), **Becroft Limited** (in liquidation), **Blue Chip Joint Ventures Limited** (in liquidation), **Blue Jay Holdings Limited** (in liquidation), **Blue Sky Holdings Limited** (in liquidation), **Bradshaw Limited** (in liquidation), **Denby Limited** (in liquidation), **Iminster Limited** (in liquidation), **Kingsley Limited** (in liquidation), **Lanark Limited** (in liquidation), **LTS Limited** (in liquidation), **McKeefry Limited** (in liquidation), **Pendale Limited** (in liquidation), **Strowan Limited** (in liquidation) and **The Landings Management Services Limited** (in liquidation)

#### Notice of Appointment of Liquidators

*Pursuant to Section 255(2)(a) of the Companies Act 1993*

Jeffrey Philip Meltzer, Arron Leslie Heath and Lloyd James Hayward, chartered accountants, were appointed joint and several liquidators of the above-named companies on 12 February 2008 at 7.00pm, pursuant to section 241(2)(a) of the Companies Act 1993.

#### Notice to Creditors to Prove Debts or Claims

Notice is given that the liquidators of the above-named companies fix 18 March 2008, as the day on or before which the creditors of the companies are to make their claims and to establish any priority their claims may have, under section 312 of the Companies Act 1993, or to be excluded from the benefit of any distribution made before their claims are made or, as the case may be, from objecting to any distribution.

Dated this 15th day of February 2008.

L. J. HAYWARD, Liquidator.

*The Address and Contact Numbers to Which, During Normal Business Hours, Enquiries May be Directed by a Creditor or Member:* Meltzer Mason Heath, Chartered Accountants, PO Box 6302, Wellesley Street, Auckland 1141. Telephone: (09) 357 6150. Facsimile: (09) 357 6152.

*Enquiries to:* Lloyd Hayward.

al1101

**Bribanc Property Group Limited** (in liquidation), **ART Apartments Limited** (in liquidation) and **Auckland Residential Tenancies Limited** (in liquidation)

#### Notice of Appointment of Liquidators

*Pursuant to Section 255(2)(a) of the Companies Act 1993*

Jeffrey Philip Meltzer, Arron Leslie Heath and Lloyd James Hayward, chartered accountants, were appointed joint and several liquidators of Bribanc Property Group Limited (in liquidation), ART Apartments Limited (in liquidation) and Auckland Residential Tenancies Limited (in liquidation) on 8 February 2008 at 6.15pm, pursuant to section 241(2)(a) of the Companies Act 1993.

#### Notice to Creditors to Prove Debts or Claims

Notice is given that the liquidators of the above-named companies fix 18 March 2008, as the day on or before which the creditors of the companies are to make their claims and to establish any priority their claims may have, under section 312 of the Companies Act 1993, or to be excluded from the benefit of any distribution made before their claims are made or, as the case may be, from objecting to any distribution.

Dated this 15th day of February 2008.

L. J. HAYWARD, Liquidator.

*The Address and Contact Numbers to Which, During Normal Business Hours, Enquiries May be Directed by a Creditor or Member:* Meltzer Mason Heath, Chartered Accountants, PO Box 6302, Wellesley Street, Auckland 1141. Telephone: (09) 357 6150. Facsimile: (09) 357 6152.

*Enquiries to:* Lloyd Hayward.

al1100

**C & W Schwass Limited** (trading as **Charade\***) (in liquidation)

#### Notice of Appointment of Liquidators

*Pursuant to Section 255(2)(a) of the Companies Act 1993*

Jeffrey Philip Meltzer and Lloyd James Hayward, chartered accountants, were appointed joint and several liquidators of C & W Schwass Limited (in liquidation) on 11 February 2008 at 9.00am, pursuant to section 241(2)(a) of the Companies Act 1993.

#### Notice to Creditors to Prove Debts or Claims

Notice is given that the liquidators of C & W Schwass Limited (in liquidation) fix 14 March 2008, as the day on or before which the creditors of the company are to make their claims and to establish any priority their claims may have, under section 312 of the Companies Act 1993, or to be excluded from the benefit of any distribution made before their claims are made or, as the case may be, from objecting to any distribution.

Dated this 14th day of February 2008.

J. P. MELTZER, Liquidator.

*The Address and Contact Numbers to Which, During Normal Business Hours, Enquiries May be Directed by a Creditor or Member:* Meltzer Mason Heath, Chartered Accountants, PO Box 6302, Wellesley Street, Auckland 1141. Telephone: (09) 357 6150. Facsimile: (09) 357 6152.

*Enquiries to:* Mike Lamacraft.

\*This notice refers to Charade stores in Hamilton and Wellington only.

al1029

**Nimbus Holdings Limited** (in liquidation)

#### Notice of Appointment of Liquidators

*Pursuant to Section 255(2)(a) of the Companies Act 1993*

Notice is given that on 13 February 2008 at 3.00pm, a special resolution was passed by the shareholders stating that the company be wound up voluntarily and Jeffrey Philip Meltzer and Karen Betty Mason be appointed as liquidators.

A solvency certificate has been filed in accordance with section 243(9) of the Companies Act 1993.

#### Notice to Creditors to Prove Debts or Claims

Notice is given that the liquidators of Nimbus Holdings Limited (in liquidation) fix 17 March 2008, as the day on or before which the creditors of the company are to make their claims and to establish any priority their claims may have, under section 312 of the Companies Act 1993, or to be excluded from the benefit of any distribution made before their claims are made or, as the case may be, from objecting to the distribution.

Dated this 15th day of February 2008.

K. B. MASON, Liquidator.

*The Address and Contact Numbers to Which, During Normal Business Hours, Enquiries May be Directed by a Creditor or Member:* Meltzer Mason Heath, Chartered Accountants, PO Box 6302, Wellesley Street, Auckland 1141. Telephone: (09) 357 6150. Facsimile: (09) 357 6152.

*Enquiries to:* Karen Mason.

Explanation: The shareholders of Nimbus Holdings Limited (in liquidation) wish to liquidate the above-named solvent company which is no longer trading.

al1104

**Sandra and Nick Limited** (trading as **Greenacres Gardening**) (in liquidation)

**Notice of Appointment of Liquidators and Notice to Creditors to Prove Debts or Claims**

Notice is hereby given that, in accordance with section 241 of the Companies Act 1993, the shareholders of the above-named company on 9 February 2008 at 1.35pm, appointed John Trevor Whittfield and Boris van Delden, insolvency practitioners of Auckland, jointly and severally as liquidators of the above-named company.

The undersigned does hereby fix Monday, 10 March 2008, as the day on or before which the creditors of the company are to prove their debts or claims and to establish any title they may have to priority, under section 312 of the Companies Act 1993, or to be excluded from the benefit of any distribution made before the debts are proved or, as the case may be, from objecting to the distribution.

JOHN T. WHITTFIELD, Liquidator.

*Date of Liquidation:* 9 February 2008.

*Address of Liquidators:* McDonald Vague, PO Box 6092, Wellesley Street Post Office, Auckland. Telephone: (09) 303 0506. Facsimile: (09) 303 0508. Website: www.mvp.co.nz

*Enquiries to:* Kevin Bromwich. Telephone: (09) 303 9514.

al1105

**Pritam Holdings Limited\*** (in liquidation)

**Notice of Appointment of Liquidators and Notice to Creditors to Prove Debts or Claims**

Notice is hereby given that, in accordance with section 241 of the Companies Act 1993, the shareholders of the above-named company on 11 February 2008 at 4.00pm, appointed Boris van Delden and John Trevor Whittfield, insolvency practitioners of Auckland, jointly and severally as liquidators of the above-named company.

The undersigned does hereby fix 28 March 2008, as the day on or before which the creditors of the company are to prove their debts or claims and to establish any title they may have to priority, under section 312 of the Companies Act 1993, or to be excluded from the benefit of any distribution made before the debts are proved or, as the case may be, from objecting to the distribution.

BORIS VAN DELDEN, Liquidator.

*Date of Liquidation:* 11 February 2008.

*Address of Liquidators:* McDonald Vague, PO Box 6092, Wellesley Street Post Office, Auckland. Telephone: (09) 303 0506. Facsimile: (09) 303 0508. Website: www.mvp.co.nz

*Enquiries to:* Boris van Delden. Telephone: (09) 306 3342.

\*Formerly known as Soap Manufacturing Limited until 1 February 2008.

al1004

**One Broadcast Limited** (in liquidation)

**Notice of Appointment of Liquidators and Notice to Creditors to Prove Debts or Claims**

Notice is hereby given that, in accordance with section 241 of the Companies Act 1993, the shareholders of the above-named company on 12 February 2008 at 1.40pm,

appointed Boris van Delden and John Trevor Whittfield, insolvency practitioners of Auckland, jointly and severally as liquidators of the above-named company.

The undersigned does hereby fix Tuesday, 18 March 2008, as the day on or before which the creditors of the company are to prove their debts or claims and to establish any title they may have to priority, under section 312 of the Companies Act 1993, or to be excluded from the benefit of any distribution made before the debts are proved or, as the case may be, from objecting to the distribution.

BORIS VAN DELDEN, Liquidator.

*Date of Liquidation:* 12 February 2008.

*Address of Liquidators:* McDonald Vague, PO Box 6092, Wellesley Street Post Office, Auckland. Telephone: (09) 303 0506. Facsimile: (09) 303 0508. Website: www.mvp.co.nz

*Enquiries to:* Daniel Zhang. Telephone: (09) 306 3340.

al1064

**ANZ Teleport & Broadcast Limited** (in liquidation)

**Notice of Appointment of Liquidators and Notice to Creditors to Prove Debts or Claims**

Notice is hereby given that, in accordance with section 241 of the Companies Act 1993, the shareholders of the above-named company on 12 February 2008 at 1.40pm, appointed John Trevor Whittfield and Boris van Delden, insolvency practitioners of Auckland, jointly and severally as liquidators of the above-named company.

The undersigned does hereby fix Tuesday, 18 March 2008, as the day on or before which the creditors of the company are to prove their debts or claims and to establish any title they may have to priority, under section 312 of the Companies Act 1993, or to be excluded from the benefit of any distribution made before the debts are proved or, as the case may be, from objecting to the distribution.

BORIS VAN DELDEN, Liquidator.

*Date of Liquidation:* 12 February 2008.

*Address of Liquidators:* McDonald Vague, PO Box 6092, Wellesley Street Post Office, Auckland. Telephone: (09) 303 0506. Facsimile: (09) 303 0508. Website: www.mvp.co.nz

*Enquiries to:* Daniel Zhang. Telephone: (09) 306 3356.

al1063

**Speight Enterprises Limited** (in liquidation)

**Notice of Appointment of Liquidators and Notice to Creditors to Prove Debts or Claims**

Notice is hereby given that, subsequent to a resolution as to solvency and in accordance with section 241(2)(a) of the Companies Act 1993, the shareholders of the above-named company on 13 February 2008 at 10.30am, appointed Victoria Toon and Peri Micaela Finnigan, chartered accountants of Auckland, jointly and severally as liquidators of the above-named company.

The undersigned does hereby fix 20 March 2008, as the day on or before which the creditors of the company are to prove their debts or claims and to establish any title they may have to priority, under section 312 of the Companies Act 1993, or to be excluded from the benefit of any distribution made before the debts are proved or, as the case may be, from objecting to the distribution.

VICTORIA TOON, Liquidator.

*Date of Liquidation:* 13 February 2008.

*Address of Liquidators:* McDonald Vague, Chartered Accountants, PO Box 6092, Wellesley Street Post



Office, Auckland. Telephone: (09) 303 0506. Facsimile: (09) 303 0508.

*Enquiries to:* Victoria Toon.

*Note:* This is a solvent liquidation and the liquidation is a result of the restructuring of the business affairs of the shareholders.

al1043

### **Orewa Health Care Center Limited (in liquidation)**

#### **Public Notice of Appointment of Liquidator and Notice to Creditors to Prove Debts or Claims**

*Pursuant to Section 3, 255(2)(a) of the Companies Act 1993*

On 15 February 2008, it was resolved by special resolution of the shareholders, pursuant to section 241(2)(a) of the Companies Act 1993, that Orewa Health Care Center Limited (in liquidation) be liquidated and that Robert Foster, chartered accountant of Auckland, be appointed liquidator for the purpose.

A certificate of solvency, pursuant to section 243(8) of the Companies Act 1993, has been completed by the directors.

The liquidation commenced on 15 February 2008 at 2.00pm.

The liquidator fixes 25 March 2008, as the day on or before which the creditors of the company are to prove their debts or claims and to establish any title they may have to priority, under section 312 of the Companies Act 1993, or to be excluded from the benefit of any distribution made before the debts are claimed or, as the case may be, from objecting to the distribution.

Creditors and shareholders may direct enquiries to the liquidator during normal business hours at the address and contact numbers stated below.

Dated this 15th day of February 2008.

ROBERT FOSTER, Liquidator.

*Address of Liquidator:* BDO Spicers, Chartered Accountants, 29 Northcroft Street, Takapuna, Auckland. Telephone: (09) 486 2125. Facsimile: (09) 486 4026.

al1143

### **Bader Limited (in liquidation)**

#### **Notice of Appointment of Liquidators**

*Address of Registered Office:* C/o Montgomerie & Associates, Albert Plaza, 87-89 Albert Street, Auckland 1130.

Bernard Spencer Montgomerie and Stuart James Cunningham were appointed joint and several liquidators of the company, pursuant to section 241(2)(a) of the Companies Act 1993, on 8 February 2008 at 10.30am.

#### **Notice to Creditors to Prove Debts or Claims**

Notice is given that the liquidators fix 12 March 2008, as the day on or before which the creditors of the company are to make their claims and to establish any priority their claims may have, under section 312 of the Companies Act 1993, or to be excluded from the benefit of any distribution made before their claims are made or, as the case may be, from objecting to the distribution.

#### **Notice of Intention to Remove**

Application to remove the above-named company will be made to the Registrar, pursuant to section 318(1)(e) of the Companies Act 1993, on the grounds that the documents referred to in section 257(1)(a) will be sent to the Registrar after 30 working days from the date of this notice.

Objections to remove, under section 321, must be delivered to the Registrar within that period.

Dated this 12th day of February 2008.

BERNARD SPENCER MONTGOMERIE, Liquidator.

*The Address and Contact Numbers to Which, During Normal Business Hours, Enquiries May be Directed by a Creditor or Member:* Montgomerie & Associates, Insolvency Practitioners, PO Box 65, Auckland 1140. Telephone: (09) 368 7672.

*Note:* The above-named insolvent company was placed into liquidation following the company ceasing to trade and losses. The shareholder has resolved to liquidate the company.

al994

### **Coverdale Properties Limited (in liquidation)**

#### **Notice of Appointment of Liquidator and Notice to Creditors to Claim**

The shareholders of the company resolved, pursuant to section 241(2)(a) of the Companies Act 1993, that Gordon L. Hansen, chartered accountant of Christchurch, be appointed liquidator.

The liquidation commenced on 7 February 2008 at 4.00pm.

Creditors of the company are to file their claims with the liquidator and to establish any priority their claims may have on or before 20 working days from the date of this notice.

Creditors and shareholders may direct enquiries to the liquidator during normal business hours at the address and contact numbers stated below.

G. L. HANSEN, Liquidator.

*Address of Liquidator:* Goldsmith Fox PKF, PO Box 13141, Christchurch. Telephone: (03) 366 6706. Facsimile: (03) 366 0265.

*Note:* The company is being liquidated as part of the restructuring of the business affairs of the shareholders. A certificate of solvency has been signed by the director of the company.

al985

### **Token Investments Limited (in liquidation)**

#### **Notice of Appointment of Liquidator and Notice to Creditors to Claim**

The shareholders of the company resolved, pursuant to section 241(2)(a) of the Companies Act 1993, that Gavin James Shepherd, chartered accountant of Christchurch, be appointed liquidator.

The liquidation commenced on Friday, 8 February 2008 at 2.00pm.

Creditors of the company are to file their claims with the liquidator and to establish any priority their claims may have on or before 8 March 2008.

Creditors and shareholders may direct enquiries to the liquidator during normal business hours at the address and contact numbers stated below.

G. J. SHEPHERD, Liquidator.

*Address for Service:* Miller Gale & Winter, PO Box 270, Christchurch. Telephone: (03) 379 5566. Facsimile: (03) 365 6915.

*Note:* The company is being liquidated as part of the restructuring of the business affairs of the shareholders. A certificate of solvency has been signed by the director of the company.

al980

### **Strand Fisk & Muldoon Limited (in liquidation)**

#### **Notice of Appointment of Liquidators**

Notice is hereby given that, pursuant to section 241(2)(a) of the Companies Act 1993, Edward Jansen and Brian Walshe



were appointed joint and several liquidators of Strand Fisk & Muldoon Limited (in liquidation).

The liquidation commenced on 15 February 2008 at 9.00am.

**Notice to Creditors to Claim**

Notice is also given that the liquidators hereby fix Thursday, 6 March 2008, as the day on or before which the creditors of the company are to make their claims and to establish any priority their claims may have under section 312 of the Companies Act 1993.

Enquiries may be directed by a creditor or shareholder of the company during normal business hours to Edward Jansen at PO Box 30568, Lower Hutt, or telephone (04) 569 9069.

EDWARD JANSEN, Liquidator, WHK Sherwin Chan & Walshe (a division of WHK (NZ) Limited).

al1010

**QCG Finance Limited** (in liquidation)

**Notice of Appointment of Liquidator**

On 12 February 2008 at 5.00pm, Raymond Gordon Burgess was appointed liquidator of the above-named company.

**Notice to Creditors to Prove Debts or Claims**

Notice is given that the liquidator fixes 21 March 2008, as the day on or before which the creditors of the above-named company are to make their claims and to establish any priority their claims may have, under section 312 of the Companies Act 1993, or to be excluded from the benefit of any distribution made before their claims are made or, as the case may be, from objecting to the distribution.

RAYMOND G. BURGESS, Liquidator.

*Address for Service:* PO Box 82100, Auckland. Telephone: (09) 576 7806. Facsimile: (09) 576 7263.

*Note:* A notice of solvency resolution has been filed for the company.

al1105

**EE Jay Marketers Limited** (in liquidation)

**Notice of Appointment of Liquidator and Notice to Creditors to Prove Debts or Claims**

I, Mark van Rossem, chartered accountant, was appointed liquidator of EE Jay Marketers Limited (in liquidation) on 14 February 2008 at 12.00 midday.

The undersigned does hereby fix 20 March 2008, as the day on or before which the creditors of the company are to make their claims and to establish any priority their claims may have, under section 312 of the Companies Act 1993, or to be excluded from the benefit of any distribution made before their claims are made or, as the case may be, from objecting to any distribution.

MARK VAN ROSSEM, Liquidator.

*Address for Service:* TVR Chartered Accountants Limited, PO Box 8155, Symonds Street, Auckland. Telephone: (09) 373 4634. Facsimile: (09) 368 1600.

al1120

**Blues Contracting Limited**

**Notice of Appointment of Liquidator**

*Pursuant to Section 255(2) of the Companies Act 1993*

In the matter of section 241(2)(c) of the Companies Act 1993, and in the matter of **Blues Contracting Limited:**

Notice is hereby given that the company was placed into liquidation on 11 February 2008 at 1.05pm, with the appointment of Scott Greer as liquidator for the company.

The liquidator fixes 31 March 2008, as the day on or before which the creditors of the company are to prove their debts

or claims and to establish any title they may have to priority, under section 312 of the Companies Act 1993, or to be excluded from the benefit of any distribution made before the debts are proved or, as the case may be, from objecting to the distribution.

Dated at Auckland this 15th day of February 2008.

SCOTT GREER.

*Address for Service:* Scott Greer, PO Box 2422, Shortland Street, Auckland. Telephone/Facsimile: (09) 526 0748.

al1083

**Marble Magic Limited** (in receivership and in liquidation)

**Notice of Appointment of Liquidators and Notice to Creditors to Claim**

Notice is hereby given that the liquidation of the above-named company commenced on 14 February 2008 at 11.02am, when the High Court at Auckland appointed Grant Robert Graham and Brendon James Gibson joint and several liquidators in accordance with section 241(2)(c) of the Companies Act 1993.

The undersigned does hereby fix 6 March 2008, as the date on or before which the creditors of the company are to make their claims and to establish any priority their claims may have, under section 312 of the Companies Act 1993, or to be excluded from the benefit of any distribution made before the debts are proved or, as the case may be, from objecting to the distribution.

If any creditor claims a security interest over any assets of the above-named company, please provide details to the liquidators forthwith.

G. R. GRAHAM and B. J. GIBSON, Joint and Several Liquidators.

*Creditors and Members May Direct Their Enquiries to the Liquidators:* KordaMentha, Level 16, Tower Centre, 45 Queen Street (PO Box 982), Auckland. Telephone: (09) 307 7865. Facsimile: (09) 377 7794.

*All Enquiries to:* Michele Raymond.

al1091

**Stewart Island Investments Limited** (in liquidation)

**Notice of Appointment of Liquidators**

Rhys James Cain, insolvency practitioner, and Malcolm Grant Hollis, chartered accountant, both of Christchurch, were appointed joint and several liquidators of Stewart Island Investments Limited by the High Court at Rotorua on 11 February 2008 at 12.22pm.

**Notice to Creditors to Claim**

Notice is given that as liquidators of Stewart Island Investments Limited, we fix 11 March 2008, as the day on or before which the creditors of the company are to make their claims and to establish any priority their claims may have, under section 312 of the Companies Act 1993, or to be excluded from the benefit of any distribution made before the debts are claimed or, as the case may be, from objecting to the distribution.

Dated this 14th day of February 2008.

MALCOLM HOLLIS, Liquidator.

*Claims Are to be Forwarded and Creditors and Shareholders May Direct Enquiries to:* Stewart Island Investments Limited (in liquidation), c/o PricewaterhouseCoopers, 119 Armagh Street (PO Box 13244), Christchurch. Telephone: (03) 374 3000. Facsimile: (03) 374 3001 (*Attention:* Rebecca Almond).

al1062

**T & J Te Huna Contracting Limited** (in liquidation)**Notice of Appointment of Liquidators**

Rhys James Cain, insolvency practitioner, and Malcolm Grant Hollis, chartered accountant, both of Christchurch, were appointed joint and several liquidators of T & J Te Huna Contracting Limited by the High Court at Wanganui, pursuant to section 241(2)(c) of the Companies Act 1993 ("the Act"), on 13 February 2008 at 10.46am.

**Notice to Creditors to Claim**

Notice is also given that as liquidators of T & J Te Huna Contracting Limited, we fix 13 March 2008, as the day on or before which creditors of the company are to make claims and to establish any priority their claims may have, under section 312 of the Companies Act 1993, or to be excluded from the benefit of any distribution made before the debts are claimed or, as the case may be, from objecting to the distribution.

Dated this 14th day of February 2008.

RHYS CAIN, Liquidator.

*Claims Are to be Forwarded and Creditors and Shareholders May Direct Enquiries to:* T & J Te Huna Contracting Limited (in liquidation), c/o PricewaterhouseCoopers, 119 Armagh Street (PO Box 13244), Christchurch. Telephone: (03) 374 3000. Facsimile: (03) 374 3001 (*Attention:* Rebecca Almond).

al1058

**GHH Leasing Limited** (in liquidation)**Public Notice of Appointment of Liquidator**

*The Companies Act 1993*

On 21 January 2008, it was resolved by special resolution, pursuant to section 241(2)(a) of the Companies Act 1993, that the company be liquidated and that Grant Mackintosh, insolvency practitioner of Hamilton, be appointed liquidator.

The liquidation commenced on 21 January 2008.

**Notice to Creditors to Claim**

Notice is also given that the liquidator hereby fixes 14 March 2008, as the day on or before which the creditors of the company are to prove their debts or claims and to establish any title that they may have to priority, under section 204 of the Companies Act 1993, or to be excluded from the benefit of any distribution made before the debts are proved or, as the case may be, from objecting to the distribution.

Creditors and shareholders may direct enquiries to the liquidator during normal business hours at the address and contact numbers stated below.

Dated this 12th day of February 2008.

GRANT MACKINTOSH, Liquidator.

*Address for Service:* PO Box 794, Hamilton. Telephone: (07) 839 5725. Facsimile: (07) 838 2881.

al1066

**Nippon Meat Packers New Zealand Limited**

(in liquidation)

**Notice of Appointment of Liquidator and Notice to Creditors to Claim**

Notice is given that by way of resolution of the shareholders of the above-named company in accordance with section 122 of the Companies Act 1993, Douglas Kim Fisher, chartered accountant of Auckland, was appointed liquidator of the company on 15 February 2008.

The liquidation commenced on 15 February 2008 at 11.00am.

The liquidator does hereby fix Thursday, 6 March 2008, as the day on or before which the creditors of the company

are to make their claims and to establish any priority their claims may have, under section 312 of the Companies Act 1993, or to be excluded from the benefit of any distribution made before their claims are made or, as the case may be, from objecting to any distribution.

D. K. FISHER, Liquidator.

*Address of Liquidator:* Douglas Kim Fisher, Private Bag MBE M215, Auckland. Telephone: (09) 630 0491. Facsimile: (09) 638 6283.

al1089

**Randrup Construction Limited** (in liquidation)**Public Notice of Appointment of Liquidator**

*The Companies Act 1993*

On 7 December 2007, it was resolved by special resolution, pursuant to section 241(2)(a) of the Companies Act 1993, that Randrup Construction Limited be liquidated and that Kim S. Thompson, insolvency practitioner of Hamilton, be appointed liquidator.

The liquidation commenced on 13 February 2008.

**Notice to Creditors to Claim**

Notice is also given that the liquidator hereby fixes 18 March 2008, as the day on or before which the creditors of the company are to prove their debts or claims and to establish any title that they may have to priority, under section 304 of the Companies Act 1993, or to be excluded from the benefit of any distribution made before the debts are proved or, as the case may be, from objecting to the distribution.

Creditors and shareholders may direct enquiries to me during normal business hours at the address and contact numbers stated below.

Dated this 13th day of February 2008.

KIM S. THOMPSON, Liquidator.

*Address of Liquidator:* PO Box 1027, Hamilton. Telephone: (07) 834 6027. Facsimile: (07) 834 6104.

*Note:* A solvency certificate has been filed in accordance with section 243(9) of the Companies Act 1993 and the shareholders wish to liquidate the above-named solvent company as it is no longer trading.

al1056

**Southwark Street Investments Limited**

(in liquidation)

**Public Notice of Appointment of Liquidators and Notice to Creditors to Prove Debts or Claims**

*The Companies Act 1993*

On 13 February 2008 at 11.00am, it was resolved by special resolution, pursuant to section 241 of the Companies Act 1993, that the above-named company be put into liquidation and Amanda-Jane Atkins and Glen David Gernhoefer, chartered accountants of Auckland, be appointed liquidators of Southwark Street Investments Limited (in liquidation) for that purpose.

The liquidation commenced on 13 February 2008 at 11.00am.

The liquidators do hereby fix 25 March 2008, as the day on or before which the creditors of the company are to make their claims and to establish any priority their claims may have under section 312 of the Companies Act 1993.

Creditors and the shareholder may direct enquiries to us during normal business hours at the address and contact numbers stated below.

Dated this 21st day of February 2008.

AMANDA-JANE ATKINS and GLEN DAVID GERNHOEFER, Liquidators.

*Address for Service:* WHK Gosling Chapman Partnership, Level 6, WHK Gosling Chapman Tower, 51–53 Shortland Street, Auckland 1010. *Postal Address:* PO Box 158, Auckland 1140. Telephone: (09) 303 4586. Facsimile: (09) 309 1198.

*Enquiries to:* Lisa McGowan. Telephone: (09) 968 8521.

*Note:* This company is solvent and the liquidation is a result of the restructuring of the affairs of the shareholder.

al1033

### **D J & P L Zander Limited** (in liquidation)

#### **Notice of Appointment of Liquidator and Notice to Creditors to Claims**

Notice is hereby given that, in accordance with section 241 of the Companies Act 1993, the shareholders of the above-named company, on 11 December 2007 at 4.00pm, appointed Robert Knyvett, chartered accountant of Accumulus Katikati, as liquidator of the above-named company.

The undersigned does hereby fix 15 March 2008, as the day on or before which any creditors of the company are to prove their debts or claims and to establish any title they may have to priority, under section 312 of the Companies Act 1993, or to be excluded from the benefit of any distribution made before the debts are proved or, as the case may be, from objecting to the distribution.

ROBERT B. KNYVETT, Liquidator.

*Address of Liquidator:* Accumulus, Chartered Accountants, 109B Main Road (PO Box 202), Katikati. Telephone: (07) 549 0977. Facsimile: (07) 549 1632.

al1060

### **Rattray Properties Limited** (in liquidation)

#### **Public Notice of Appointment of Liquidators**

Notice is hereby given that, pursuant to section 241(2)(a) of the Companies Act 1993, Stephen James Higgs and Henry Martin van Dyk, chartered accountants of Polson Higgs, were appointed liquidators of Rattray Properties Limited.

The liquidation commenced on 13 February 2008 at 5.00pm.

#### **Notice to Creditors to Claim**

Notice is also given that the liquidators hereby fix 13 March 2008, as the day on or before which the creditors of the company are to make their claims and to establish any priority their claims may have under section 312 of the Companies Act 1993.

Enquiries may be directed by a creditor or shareholder of the company during normal business hours to Jiahua Su at 139 Moray Place, Dunedin, or telephone (03) 479 4823.

Dated this 21st day of February 2008.

STEPHEN JAMES HIGGS and HENRY MARTIN VAN DYK, Liquidators.

*Address for Service:* Polson Higgs, PO Box 5346, Dunedin.

al1037

### **Ambition Wholesalers Limited** (in liquidation)

#### **Notice of Appointment of Liquidators**

*The Companies Act 1993*

Notice is hereby given that on 11 February 2008 at 10.10am, it was resolved by special resolution of shareholders, pursuant to section 241(2)(a) of the Companies Act 1993, that Ambition Wholesalers Limited be liquidated and that Stephen Mark Lawrence and Anthony John McCullagh, insolvency practitioners of Horwath Corporate (Auckland) Limited, be appointed joint and several liquidators for that purpose.

### **Notice to Creditors to Prove Debts or Claims**

Notice is given that the liquidators have fixed 14 March 2008, as the day on or before which the creditors of the above-named company are to make their claims and to establish any priority their claims may have, under section 312, or to be excluded from the benefit of any distribution made before the claims are made or, as the case may be, from objecting to the distribution.

Creditors and members may direct enquiries to the liquidator during normal business hours at the address and contact numbers stated below.

STEPHEN MARK LAWRENCE and ANTHONY JOHN McCULLAGH, Liquidator.

*The Contact Address is:* Horwath Corporate (Auckland) Limited, PO Box 3678, Auckland 1140. Telephone: (09) 306 7421. Facsimile: (09) 302 0536.

*Attention:* Steve Lawrence.

al1038

### **Backspace Limited** (in liquidation)

#### **Public Notice of Appointment of Liquidators**

*Pursuant to Section 3, 255(2)(a) of the Companies Act 1993*

On 8 February 2008, it was resolved by the directors and shareholders that Backspace Limited be liquidated and that Gregory Noel Rathbun and Richard Charles Ashby, chartered accountants of Auckland, be appointed joint liquidators for the purpose.

The liquidation commenced on 12 February 2008.

Creditors and shareholders may direct enquiries to us during normal business hours at the address and contact numbers stated below.

G. N. RATHBUN and R. C. ASHBY, Liquidators.

*Address for Service:* PO Box 6310, Wellesley Street, Auckland. Telephone: (09) 309 5191. Facsimile: (09) 309 5260.

al1052

### **Riverpark Limited** (in liquidation)

#### **Public Notice of Appointment of Liquidators**

*Pursuant to Section 3, 255(2)(a) of the Companies Act 1993*

On 8 February 2008, it was resolved by the directors and shareholders that Riverpark Limited be liquidated and that Gregory Noel Rathbun and Richard Charles Ashby, chartered accountants of Auckland, be appointed joint liquidators for the purpose.

The liquidation commenced on 12 February 2008.

Creditors and shareholders may direct enquiries to us during normal business hours at the address and contact numbers stated below.

G. N. RATHBUN and R. C. ASHBY, Liquidators.

*Address for Service:* PO Box 6310, Wellesley Street, Auckland. Telephone: (09) 309 5191. Facsimile: (09) 309 5260.

al1053

### **Sanctuary Developments (Columbia) Limited** (in liquidation)

#### **Public Notice of Appointment of Liquidators**

*Pursuant to Section 3, 255(2)(a) of the Companies Act 1993*

On 8 February 2008, it was resolved by the directors and shareholders that Sanctuary Developments (Columbia) Limited be liquidated and that Gregory Noel Rathbun and Richard Charles Ashby, chartered accountants of Auckland, be appointed joint liquidators for the purpose.



The liquidation commenced on 12 February 2008.  
Creditors and shareholders may direct enquiries to us during normal business hours at the address and contact numbers stated below.

G. N. RATHBUN and R. C. ASHBY, Liquidators.  
*Address for Service:* PO Box 6310, Wellesley Street, Auckland. Telephone: (09) 309 5191. Facsimile: (09) 309 5260.

al1051

### **Sanctuary Developments (Portobello Terraces) Limited** (in liquidation)

#### **Public Notice of Appointment of Liquidators**

*Pursuant to Section 3, 255(2)(a) of the Companies Act 1993*

On 8 February 2008, it was resolved by the directors and shareholders that Sanctuary Developments (Portobello Terraces) Limited be liquidated and that Gregory Noel Rathbun and Richard Charles Ashby, chartered accountants of Auckland, be appointed joint liquidators for the purpose.

The liquidation commenced on 12 February 2008.

Creditors and shareholders may direct enquiries to us during normal business hours at the address and contact numbers stated below.

G. N. RATHBUN and R. C. ASHBY, Liquidators.  
*Address for Service:* PO Box 6310, Wellesley Street, Auckland. Telephone: (09) 309 5191. Facsimile: (09) 309 5260.

al1050

### **Tri Produce (1999) Limited** (in liquidation)

#### **Notice of Appointment of Liquidator and Notice to Creditors to Claim**

Notice is hereby given that, pursuant to section 241(2)(a) of the Companies Act 1993, the undersigned was appointed liquidator of the above-named company by a special resolution of the shareholders.

A certificate of solvency, pursuant to section 243(8) of the Companies Act 1993, has been completed by the directors.

The liquidation commenced on 14 February 2008.

The undersigned does hereby fix 20 March 2008, as the day on or before which the creditors of the company are to prove their debts or claims and to establish any priority their claims may have under section 312 of the Companies Act 1993.

Dated this 15th day of February 2008.

W. G. CANT.

*Address for Service:* Level 7, Southern Cross Building, 61 High Street, Auckland. Telephone: (09) 309 2040.

*Note:* This is a solvent company that has ceased trading.

al1088

### **Tri Produce Company Limited** (in liquidation)

#### **Notice of Appointment of Liquidator and Notice to Creditors to Claim**

Notice is hereby given that, pursuant to section 241(2)(a) of the Companies Act 1993, the undersigned was appointed liquidator of the above-named company by a special resolution of the shareholders.

A certificate of solvency, pursuant to section 243(8) of the Companies Act 1993, has been completed by the directors.

The liquidation commenced on 14 February 2008.

The undersigned does hereby fix 20 March 2008, as the day on or before which the creditors of the company are to prove their debts or claims and to establish any priority their

claims may have under section 312 of the Companies Act 1993.

Dated this 15th day of February 2008.

W. G. CANT.

*Address for Service:* Level 7, Southern Cross Building, 61 High Street, Auckland. Telephone: (09) 309 2040.

*Note:* This is a solvent company that has ceased trading.

al1082

### **Brown & Taylor Holdings Limited** (formerly **Taylor's Floorcoverings & Furnishings Limited**)

#### **Notice of Appointment of Liquidator**

*Pursuant to Section 255(2)(a) of the Companies Act 1993*

*Company No.:* 138555

I, Andrew Marchel Oorschot, hereby give notice that, for the purpose of winding up a solvent, non-trading company and pursuant to section 241(2)(a) of the Companies Act 1993, I was appointed as liquidator of Brown & Taylor Holdings Limited with effect from 5 February 2008 at 3.00pm.

#### **Notice of Meeting of Creditors**

The directors have resolved that the company was solvent prior to my appointment and therefore, pursuant to section 243(8), no creditors' meeting is required to be called.

#### **Notice to Creditors to Claim**

*Pursuant to Liquidation Regulation 12 of the Companies Act 1993*

Notice is hereby given that as liquidator of Brown & Taylor Holdings Limited (in liquidation), I fix 13 March 2008, as the day on or before which the creditors of the company are to make their claims and to establish any priority their claims may have, under section 312 of the Companies Act 1993 (as amended), or to be excluded from the benefit of any distribution made before the debts are claimed or, as the case may be, from objecting to the distribution.

Enquiries by creditors and shareholders may be directed to Ashton Wheelans & Hegan, Chartered Accountants, PO Box 13042, Christchurch (telephone (03) 366 7154), during normal business hours.

Dated at Christchurch this 8th day of February 2008.

A. M. OORSCHOT, Liquidator.

*Please Note:* This is a liquidation of a solvent company. The liquidation is taking place as the company has ceased trading following the sale of its business assets. The company has sufficient funds to pay all creditors.

al1032

### **T.B.W. Holdings Limited**

#### **Notice of Appointment of Liquidator**

*Pursuant to Section 255(2)(a) of the Companies Act 1993*

*Company No.:* 875019

I, Andrew Marchel Oorschot, hereby give notice that, for the purpose of winding up a solvent, non-trading company and pursuant to section 241(2)(a) of the Companies Act 1993, I was appointed as liquidator of T.B.W. Holdings Limited with effect from 5 February 2008 at 3.00pm.

#### **Notice of Meeting of Creditors**

The directors have resolved that the company was solvent prior to my appointment and therefore, pursuant to section 243(8), no creditors' meeting is required to be called.

#### **Notice to Creditors to Claim**

*Pursuant to Liquidation Regulation 12 of the Companies Act 1993*

Notice is hereby given that as liquidator of T.B.W. Holdings Limited (in liquidation), I fix 13 March 2008, as the day

on or before which the creditors of the company are to make their claims and to establish any priority their claims may have, under section 312 of the Companies Act 1993 (as amended), or to be excluded from the benefit of any distribution made before the debts are claimed or, as the case may be, from objecting to the distribution.

Enquiries by creditors and shareholders may be directed to Ashton Wheelans & Hegan, Chartered Accountants, PO Box 13042, Christchurch (telephone (03) 366 7154), during normal business hours.

Dated at Christchurch this 8th day of February 2008.

A. M. OORSCHOT, Liquidator.

*Please Note:* This is a liquidation of a solvent company. The liquidation is taking place as the company has ceased trading following the sale of its business assets. The company has sufficient funds to pay all creditors.

al1034

## **Fun Stuff Limited**

### **Notice of Appointment of Liquidator**

*Pursuant to Section 255(2)(a) of the Companies Act 1993*

*Company No.:* 580167

I, Andrew Marchel Oorschot, hereby give notice that, for the purpose of winding up a solvent, non-trading company and pursuant to section 241(2)(a) of the Companies Act 1993, I was appointed as liquidator of Fun Stuff Limited with effect from 12 February 2008 at 5.00pm.

### **Notice of Meeting of Creditors**

The directors have resolved that the company was solvent prior to my appointment and therefore, pursuant to section 243(8), no creditors' meeting is required to be called.

### **Notice to Creditors to Claim**

*Pursuant to Liquidation Regulation 12 of the Companies Act 1993*

Notice is hereby given that as liquidator of Fun Stuff Limited (in liquidation), I fix 12 March 2008, as the day on or before which the creditors of the company are to make their claims and to establish any priority their claims may have, under section 312 of the Companies Act 1993 (as amended), or to be excluded from the benefit of any distribution made before the debts are claimed or, as the case may be, from objecting to the distribution.

Enquiries by creditors and shareholders may be directed to Ashton Wheelans & Hegan, Chartered Accountants, PO Box 13042, Christchurch (telephone (03) 366 7154), during normal business hours.

Dated at Christchurch this 12th day of February 2008.

A. M. OORSCHOT, Liquidator.

*Please Note:* This is a liquidation of a solvent company. The liquidation is taking place as the company has ceased trading following the sale of its business assets. The company has sufficient funds to pay all creditors.

al1035

## **ARL Air Conditioning and Refrigeration Limited** (in liquidation)

### **Public Notice of Appointment of Liquidator and Notice to Creditors to Claim**

*Pursuant to Section 255(2)(a) of the Companies Act 1993*

On 7 February 2008, it was resolved by special resolution, pursuant to section 241(2)(a) of the Companies Act 1993, that ARL Air Conditioning and Refrigeration Limited be liquidated and that Roderick Thomas McKenzie, of McKenzie & Partners Limited, Chartered Accountants, Palmerston North, be appointed liquidator.

The liquidation commenced on 7 February 2008 at 10.00am. The liquidator has fixed Friday, 14 March 2008, as the last day for creditors to make their claims and to establish any priority their claims may have under section 312 of the Companies Act 1993.

Creditors who have not made a claim at the date a distribution is declared will be excluded from the benefit of that distribution and may not object to that distribution.

Any enquiries may be directed to the liquidator during normal business hours at the address and contact numbers stated below.

RODERICK THOMAS MCKENZIE, Liquidator.

*Address for Service:* McKenzie & Partners Limited, Level 1, 484 Main Street (PO Box 12014), Palmerston North. Telephone: (06) 354 9639. Facsimile: (06) 356 2028.

al1011

## **Norm Bengston Limited** (in liquidation)

### **Public Notice of Appointment of Liquidator and Notice to Creditors to Claim**

*Pursuant to Section 255(2)(a) of the Companies Act 1993*

On 14 February 2008, it was resolved by special resolution, pursuant to section 241(2)(a) of the Companies Act 1993, that Norm Bengston Limited be liquidated and that Roderick Thomas McKenzie, of McKenzie & Partners Limited, Chartered Accountants, Palmerston North, be appointed liquidator.

The liquidation commenced on 14 February 2008 at 9.30am.

The liquidator has fixed Friday, 21 March 2008, as the last day for creditors to make their claims and to establish any priority their claims may have under section 312 of the Companies Act 1993.

Creditors who have not made a claim at the date a distribution is declared will be excluded from the benefit of that distribution and may not object to that distribution.

Any enquiries may be directed to the liquidator during normal business hours at the address and contact numbers stated below.

RODERICK THOMAS MCKENZIE, Liquidator.

*Address for Service:* McKenzie & Partners Limited, Level 1, 484 Main Street (PO Box 12014), Palmerston North. Telephone: (06) 354 9639. Facsimile: (06) 356 2028.

al1059

## **Ashbury Properties Limited** (in liquidation)

### **Notice of Appointment of Liquidator**

*Pursuant to the Companies Act 1993*

Notice is hereby given that the liquidation of Ashbury Properties Limited commenced on 21 December 2007 at 4.26pm, when the members appointed Murray G. Allott, chartered accountant of Christchurch, as liquidator, in accordance with section 241(2)(a) of the Companies Act 1993, by the passing of a special resolution by entry in the company minute book.

The director previously passed a resolution declaring that on the appointment of a liquidator the company would be able to pay its debts.

### **Notice of Meeting of Creditors**

Pursuant to section 243(8) of the Companies Act 1993, the liquidator is not required to call a meeting of creditors.

The company being liquidated has been certified by the director as being a solvent company.

Any enquiries by creditors or shareholders may be directed to the liquidator.

MURRAY G. ALLOTT, Liquidator.

*Address of Liquidator:* 111 Bealey Avenue, Christchurch 8013. *Postal Address:* PO Box 29432, Christchurch 8540. Telephone: (03) 365 1028. Facsimile: (03) 365 6400. Email: murray@profitco.co.nz

al125

### **Caboose Taupo Limited (in liquidation)**

#### **Notice of Appointment of Liquidator**

*Pursuant to the Companies Act 1993*

Notice is hereby given that the liquidation of Caboose Taupo Limited commenced on 21 December 2007 at 4.27pm, when the members appointed Murray G. Allott, chartered accountant of Christchurch, as liquidator, in accordance with section 241(2)(a) of the Companies Act 1993, by the passing of a special resolution by entry in the company minute book.

The director previously passed a resolution declaring that on the appointment of a liquidator the company would be able to pay its debts.

#### **Notice of Meeting of Creditors**

Pursuant to section 243(8) of the Companies Act 1993, the liquidator is not required to call a meeting of creditors.

The company being liquidated has been certified by the director as being a solvent company.

Any enquiries by creditors or shareholders may be directed to the liquidator.

MURRAY G. ALLOTT, Liquidator.

*Address of Liquidator:* 111 Bealey Avenue, Christchurch 8013. *Postal Address:* PO Box 29432, Christchurch 8540. Telephone: (03) 365 1028. Facsimile: (03) 365 6400. Email: murray@profitco.co.nz

al124

### **Sure Electrical Limited and Sure Construction Limited (both in liquidation)**

#### **Notice of Appointment of Liquidator**

*Pursuant to Section 255(2)(a) of the Companies Act 1993*

Notice is hereby given that the liquidation of the above-named companies commenced on Friday, 8 February 2008 at 2.27pm, when the members appointed Murray G. Allott, chartered accountant of Christchurch, as liquidator, in accordance with section 241(2)(a) of the Companies Act 1993, by the passing of special resolutions.

#### **Notice of Meeting of Creditors**

Pursuant to section 245 of the Companies Act 1993, the liquidators will dispense with the meetings of creditors in order to keep costs to a minimum and maximise returns to creditors.

#### **Notice to Creditors to Lodge Claims**

*Pursuant to Regulation 12(2) of the Companies Act 1993 Liquidation Regulations 1994*

The liquidator has hereby fixed Tuesday, 11 March 2008, as the last day for creditors to make their claims and establish any priority their claims may have.

Creditors who have not made a claim at the date a distribution is declared will be excluded from the benefit of that distribution and those creditors may not object to that distribution.

Any enquiries by creditors or shareholders may be directed to the liquidator.

MURRAY G. ALLOTT, Liquidator.

*Address of Liquidator:* 111 Bealey Avenue, Christchurch 8013. *Postal Address:* PO Box 29432, Christchurch 8540.

Telephone: (03) 365 1028. Facsimile: (03) 365 6400. Email: murray@profitco.co.nz

*Note:* Any creditors claiming a security interest in respect of these companies should provide details to the liquidator urgently.

al973

### **Armour Roofing Limited (in liquidation)**

#### **Notice of Appointment of Liquidator**

I, John Francis Managh, insolvency specialist of Napier, hereby give notice that by order of the High Court, Wellington, on 11 February 2008, pursuant to section 241(2)(c) of the Companies Act 1993, I was appointed liquidator of Armour Roofing Limited.

Dated this 14th day of February 2008.

JOHN MANAGH, Liquidator.

*Address for Service:* 50 Tennyson Street (PO Box 1022), Napier. Telephone/Facsimile: (06) 835 6280.

al1095

### **Appliance Servicing (2004) Limited (in liquidation)**

#### **Notice of Appointment of Liquidator and Notice to Creditors to Prove Debts**

I, John Francis Managh, of Napier, hereby give notice that by resolution of the shareholders of the company, pursuant to section 241(2)(a) of the Companies Act 1993, on 25 January 2007, I was appointed liquidator.

Proofs of debt are to be received by the liquidator no later than 15 March 2008, as failure to prove by that date may lead to late claims being excluded from any distribution.

JOHN MANAGH.

*Address for Service:* 50 Tennyson Street (PO Box 1022), Napier. Telephone/Facsimile: (06) 835 6280.

al1084

### **Beazley Bros. Transport Limited (in liquidation)**

#### **Notice of Appointment of Liquidators**

*Pursuant to Section 255(2)(a) of the Companies Act 1993*

Dennis Clifford Parsons and Katherine Louise Kenealy were appointed joint and several liquidators of Beazley Bros. Transport Limited (in liquidation) on 11 February 2008 12.28pm.

D. C. PARSONS, Liquidator.

*Address for Service:* Indepth Forensic Limited, PO Box 278, Hamilton. Telephone: (07) 957 8674. Website: www.indepth.co.nz

al1009

### **Aspiro Properties Company Limited (in liquidation)**

#### **Notice of Appointment of Liquidators**

*Pursuant to Section 255(2)(a) of the Companies Act 1993*

Dennis Clifford Parsons and Katherine Louise Kenealy were appointed joint and several liquidators of Aspiro Properties Company Limited (in liquidation) on 14 February 2008 at 10.29am.

D. C. PARSONS, Liquidator.

*Address for Service:* Indepth Forensic Limited, PO Box 278, Hamilton. Telephone: (07) 957 8674. Website: www.indepth.co.nz

al1157



## APPOINTMENT AND RELEASE OF ADMINISTRATORS

### Northern Energy Services Limited (administrators appointed)

#### Notice of Appointment of Administrators

*Company No.:* 1266938

On 14 February 2008, the company, under section 239i of the Companies Act 1993 (as amended), appointed Damien Grant and Steven Khov, of Waterstone Insolvency, as joint and several administrators.

#### Notice of First Meeting of Creditors

Notice is given that a meeting of creditors will be held at the offices of Gaze Burt Lawyers, 1st Floor, 44 Corinthian Drive, Albany, Auckland, on 26 February 2008 at 10.30am.

The purpose of the meeting is to determine:

- (a) whether to appoint a committee of creditors; and, if so,
- (b) who are to be the committee's members.

At the meeting, creditors may also by resolution:

- (a) remove the administrators from office; and
- (b) appoint someone else as administrator of the company.

#### Notice to Secured Creditors

Notice is hereby given that any person who holds a valid charge over the whole, or substantially the whole, of the company's property, has 10 workings days from the date of the administration to enforce its security, failing which it will lose its opportunity to do so, without specific leave of administrators or of the Court.

Dated this 15th day of February 2008.

DAMIEN GRANT and STEVEN KHOV, Joint Administrators.

*Enquiries May be Made to:* Waterstone Insolvency, Unit K1, 75 Corinthian Drive, Albany, Auckland. Telephone: 0800 CLOSED. Facsimile: 0800 FAXWSI.

aa1085

## REMOVALS

### Notice of Intention to Remove Companies From the Register

I intend to remove the following companies from the Register under section 318(1)(d) of the Companies Act 1993.

I am satisfied that these companies have ceased to carry on business and there is no further reason for these companies to continue in existence or that no liquidator is acting.

AFFINITI CAPITAL LIMITED.  
 AGFAPHOTO NEW ZEALAND LIMITED.  
 ALISUN 2003 LIMITED.  
 ALUCOBOND ARCHITECTURAL (NEW ZEALAND) LIMITED.  
 ALW HOLDINGS LIMITED.  
 APPLEDORE PROPERTY INVESTMENTS LIMITED.  
 ASPLET HAULAGE LIMITED.  
 AUCKLAND CITY REALTY LIMITED.  
 B BOY RIDES LIMITED.  
 BAKER FINANCIAL SERVICES LIMITED.  
 BALDWIN & BALDWIN LIMITED.  
 BAY SURGICAL IMPLANTS LIMITED.  
 BC RENTALS LIMITED.  
 BEAMISH ENTERPRISES LIMITED.  
 BENETTI HOLDINGS LIMITED.  
 BIGGS & SONS (NZ) LIMITED.  
 BK CONSTRUCTION LIMITED.  
 BLAZEON LIMITED.  
 BLUE FOUNTAIN LIMITED.  
 BRUMEE (5) LIMITED.  
 BUILDER INVESTMENTS LIMITED.  
 BUTU SERVICES LIMITED.  
 CHIPCHASE HOLDINGS LIMITED.  
 CITY MECHANICAL REPAIRS 2000 LIMITED.  
 CLANSMEN CHARTERS LIMITED.  
 CLIFF PRESS PRINTERS 2004 LIMITED.  
 CM ESTATE LIMITED.  
 DARROCH ENTERPRISES LIMITED.

EBIT NZ LIMITED.  
 EIC DIGITAL STUDIOS LIMITED.  
 EMERALD ENTERPRISE (2007) LIMITED.  
 ENDEAVOUR PROPERTIES LIMITED.  
 EURO HOLDINGS LIMITED.  
 FOREMOST INVESTMENTS LIMITED.  
 GCB INVESTMENTS LIMITED.  
 GLOBAL BUSINESS SOLUTIONS LIMITED.  
 GSB ENTERPRISES LIMITED.  
 GSB HOLDINGS LIMITED.  
 GSB PROPERTIES LIMITED.  
 GUNWALLACE HOLDINGS LIMITED.  
 H & A GODFREY LIMITED.  
 HAMMOND SHEARING CONTRACTING LIMITED.  
 HOUSE OF CAMERON LIMITED.  
 IBEX HOLDINGS LIMITED.  
 IMPORT VEHICLES LIMITED.  
 INTERNATIONAL OPEN SYSTEMS LIMITED.  
 INVESTMENT 102 LIMITED.  
 JADEWORK N.Z. LIMITED.  
 KATJA LIETZ CONSULTING LIMITED.  
 KAURI ARMS TAVERN LIMITED.  
 KB WEAR LIMITED.  
 KERIKERI FLOORING (1999) LIMITED.  
 KEV'S QUALITY MEATS LIMITED.  
 KIWI POLLEN LIMITED.  
 KIWIDOT INVESTMENTS LIMITED.  
 L.A.NISBET LIMITED.  
 LCLD LIMITED.  
 LIBL 2007 LIMITED.  
 LIDI HOLDINGS LIMITED.  
 LOMAN INVESTMENTS LIMITED.  
 M J BLACKBURN PROPERTIES LIMITED.  
 MAJOR COLE ENTERPRISES LIMITED.  
 MANDEVILLE MOTH LIMITED.  
 MARKEDO 4 MANAGEMENT LIMITED.  
 MORE THAN POTS LIMITED.

MOWBRAY MAXWELL INC. LIMITED.  
 MY EMPIRE LIMITED.  
 NANSTAR INVESTMENTS LIMITED.  
 NIKAU PROPERTY SERVICES LIMITED.  
 NORTH SOUTH EGGS LIMITED.  
 OAMARU DECOR LIMITED.  
 OBLIQUE DEVELOPMENTS LIMITED.  
 ONE TOUCH MEDICAL ALARMS LIMITED.  
 PARKER HARDWARE (1997) LIMITED.  
 PAUL BEVIN ASSOCIATES LIMITED.  
 PAYNOW BUSINESS FINANCE LIMITED.  
 PAYNOW FOR BUSINESS LIMITED.  
 PAYNOW FOR HEALTH LIMITED.  
 PAYNOW LIMITED.  
 POURERERE TRANSPORT LIMITED.  
 PRECIS LIMITED.  
 PROPERTY AND BUILDING SERVICES LIMITED.  
 RAINBOW VALLEY SKI AREA LIMITED.  
 RAMBLE PROPERTIES LIMITED.  
 RBJP LIMITED.  
 RED OAK DISTRIBUTION LIMITED.  
 RUAHINE PROPERTY TRUST LIMITED.  
 RVR COMPANY LIMITED.  
 SAFEWIRE ELECTRICAL LIMITED.  
 SCALLYWAGS CLOTHING LIMITED.  
 SHELF COMPANY NO. 556 LIMITED.  
 SHORE CAPITAL LIMITED.  
 SNIFFER NZ LIMITED.  
 SOSO LIMITED.  
 SPEEDLINER NORTH HARBOUR LIMITED.  
 SPRING INVESTMENT NEW ZEALAND LIMITED.  
 STANMORE INVESTMENTS LIMITED.  
 STONEMAN INVESTMENTS LIMITED.  
 SVR HOLDINGS LIMITED.  
 THE EURO IMAGE COMPANY LIMITED.  
 THOMAS CONSULTANTS LIMITED.  
 THOMPSON & SANGSTER LIMITED.  
 THREE HUNDRED CHURCH STREET LIMITED.  
 WAITANGI FARM LIMITED.  
 WAITATA HOLDINGS LIMITED.  
 WHIZ ELECTRICAL LIMITED.  
 WORKZ LIMITED.  
 ZENITH DEVELOPMENTS LIMITED.  
 ZHONG ZE GROUP LIMITED.

Unless, under section 321 of the Companies Act 1993, written objection to removal of any of the above-named companies is delivered to the Registrar by 20 March 2008 (being not less than 20 working days from the date of this notice), the Registrar is required to remove the companies from the Register.

Dated this 21st day of February 2008.

NEVILLE HARRIS, Registrar of Companies.

Contact for Enquiries: 0508 COMPANIES (0508 266 726).

Postal Address for Written Objections: The Registrar of Companies, Northern Business Centre, Private Bag 92061, Auckland Mail Centre.

Facsimile No. for Written Objections: (09) 916 4559.

ds1086

**Flyways Travel Limited, Decorating FX Limited, Silverdale Motors 1999 Limited, Waitomo Caves Hotel Limited and De-Amalfi Survival Limited**  
 (all in liquidation) (“the companies”)

**Notice of Intention to Remove Companies From the Register**

*Pursuant to Section 320 of the Companies Act 1993*

We, Vivian Judith Fatupaito and Richard Dale Agnew, liquidators of the above-named companies, hereby give notice that, pursuant to section 318(1)(e) of the Companies Act 1993 and having filed with the Registrar our final reports on the liquidations, it is intended to remove the companies from the New Zealand Register.

Any objection to the removals, pursuant to section 321 of the Companies Act 1993, must be delivered to the Registrar no later than 11 March 2008.

Dated this Wednesday, the 13th day of February 2008.

VIVIAN FATUPAITO, Liquidator.

ds1013

**Banson & Hegdes Limited and Cable Linx Systems Limited** (both in liquidation) (“the companies”)

**Notice of Intention to Remove Companies From the Register**

*Pursuant to Section 320 of the Companies Act 1993*

We, Vivian Judith Fatupaito and Richard Dale Agnew, liquidators of the companies, hereby give notice that, pursuant to section 318(1)(e) of the Companies Act 1993 and having filed with the Registrar our final report on each liquidation, it is intended to remove the companies from the New Zealand Register.

Any objection to the removals, pursuant to section 321 of the Companies Act 1993, must be delivered to the Registrar no later than 17 March 2008.

Dated this Monday, the 18th day of February 2008.

VIVIAN FATUPAITO, Liquidator.

ds1044

**Hetherington Plasterers Limited** (in liquidation)

**Notice of Intention to Remove Company From the Register**

*Pursuant to Section 320 of the Companies Act 1993*

We, Vivian Judith Fatupaito and John Anthony Waller, liquidators of Hetherington Plasterers Limited, hereby give notice that, pursuant to section 318(1)(e) of the Companies Act 1993 and having filed with the Registrar our final report on the liquidation, it is intended to remove the company from the New Zealand Register.

Any objection to the removal, pursuant to section 321 of the Companies Act 1993, must be delivered to the Registrar no later than 11 March 2008.

Dated this Wednesday, the 13th day of February 2008.

VIVIAN FATUPAITO, Liquidator.

ds1014

**Parkway Properties Limited** (in liquidation)

**Notice of Intention to Remove Company From the Register**

*Pursuant to Section 320 of the Companies Act 1993*

We, Jeffrey Philip Meltzer and Rachel Karen Mason, liquidators of Parkway Properties Limited (in liquidation), whose registered office is situated at Level 16, 7 City Road, Auckland, hereby give notice that, pursuant to section

318(1)(e) of the Companies Act 1993 and having filed with the Registrar our final report on the liquidation, it is intended to remove the company from the New Zealand Register.

Any objection to the removal, pursuant to section 321 of the Companies Act 1993, must be delivered to the Registrar of Companies no later than 28 March 2008.

Dated this 12th day of February 2008.

R. K. MASON, Liquidator.

*Address of Liquidators:* Meltzer Mason Heath, Level 16, 7 City Road, Auckland 1010. *Postal Address:* PO Box 6302, Wellesley Street, Auckland 1141.

ds991

### **Wellesley Hotel Limited** (in liquidation)

#### **Notice of Intention to Remove Company From the Register**

In the matter of the Companies Act 1993, and in the matter of **Wellesley Hotel Limited** (in liquidation):

Notice is hereby given, in pursuance of section 320 of the Companies Act 1993 ("the Act"), that:

- (a) It is intended that the above-named company be removed from the Register, under section 318(1)(e) of the Act, on the grounds that the duties of the liquidator have been completed and the liquidator has sent to the Registrar the documents referred to in section 257(1)(a) of the Act.
- (b) Any objection to the removal, under section 321 of the Act, must be lodged with the Registrar together with the grounds for such objection no later than 20 March 2008.

Dated at Auckland this 15th day of February 2008.

JOHN T. WHITTFIELD, Liquidator.

*Address of Liquidator and Address for Service of Company:* McDonald Vague, Insolvency Specialists, 80 Greys Avenue, Auckland. *Postal Address:* PO Box 6092, Wellesley Street, Auckland. Website: www.mvp.co.nz

ds1045

### **Main Road Limited** (in liquidation) and **Thetford Holdings Limited** (in liquidation)

#### **Notice of Application for Removal of Companies From the Register**

The liquidations of the above-named companies have been completed and the final reports and statements of receipts and payments have been sent to the Registrar, pursuant to section 257 of the Companies Act 1993, together with a request that the companies be removed from the Register pursuant to section 318(1)(e) of the Companies Act 1993.

Any objection to the removals, under section 321 of the Act, must be delivered to the Registrar within 20 working days of the date of this notice.

Dated this 15th day of February 2008.

DAVID VANCE, Liquidator.

ds1147

### **XChecker Security Limited** (struck off and in liquidation) and **Taumata Holdings 2005 Limited** (struck off and in liquidation)

#### **Notice of Application for Removal of Companies From the Register**

The liquidations of the above-named companies have been completed and the final reports and statements of receipts and payments have been sent to the Registrar, pursuant to section 257 of the Companies Act 1993.

Dated this 15th day of February 2008.

DAVID VANCE, Liquidator.

*Please Note:* The above-named companies were struck off the Register prior to the appointment of liquidators.

ds1148

### **Albany Cold Storage Limited** (in liquidation)

#### **Notice of Intention to Remove the Above-named Company From the Register**

*Pursuant to Section 320(2) of the Companies Act 1993*

*Address of Registered Office:* RES Business Development Limited, Building C, 42 Tawa Drive Office Park, Albany, Auckland 0632.

Notice is hereby given that, pursuant to section 318(1)(e) of the Companies Act 1993, the Registrar of Companies will be removing the above-named company from the Register on the grounds that the liquidators have completed their duties.

The liquidators have delivered their final report on the liquidation in terms of section 257(1) of the Companies Act 1993 to the Registrar of Companies.

Any objection to the removal, pursuant to section 321 of the Companies Act 1993, must be delivered to the Registrar of Companies no later than 11 March 2008.

Dated this 8th day of February 2008.

DIGBY JOHN NOYCE and KEITH MAWDSLEY, Joint and Several Liquidators.

ds999

### **Shore Foods Limited** (in liquidation)

#### **Notice of Intention to Remove the Above-named Company From the Register**

*Pursuant to Section 320(2) of the Companies Act 1993*

*Address of Registered Office:* RES Business Development Limited, Building C, 42 Tawa Drive Office Park, Albany, Auckland 0632.

Notice is hereby given that, pursuant to section 318(1)(e) of the Companies Act 1993, the Registrar of Companies will be removing the above-named company from the Register on the grounds that the liquidators have completed their duties.

The liquidators have delivered their final report on the liquidation in terms of section 257(1) of the Companies Act 1993 to the Registrar of Companies.

Any objection to the removal, pursuant to section 321 of the Companies Act 1993, must be delivered to the Registrar of Companies no later than 11 March 2008.

Dated this 8th day of February 2008.

DIGBY JOHN NOYCE and KEITH MAWDSLEY, Joint and Several Liquidators.

ds1000

### **Belang Developments Limited** (in liquidation)

#### **Notice of Intention to Apply for Removal of the Above-named Company From the Register**

*Pursuant to Section 320(2) of the Companies Act 1993*

*Company No.:* 1701564

I have concluded the liquidation of the above-named company and hereby give notice in accordance with section 318(1)(e)(i) of the Companies Act 1993.

I have filed my final report and consequently the company is to be removed from the Register.

Notice is given that unless written objection to the removal of the company is sent or delivered to the Registrar,



pursuant to section 321 of the Act, within 20 working days, the Registrar may remove the company from the Register.

Dated at Christchurch this 7th day of February 2008.

RICHARD NICHOLAS INESON, Liquidator.

ds983

**Buckleys Rd Developments Limited** (in liquidation)

**Notice of Intention to Apply for Removal of the Above-named Company From the Register**

*Pursuant to Section 320(2) of the Companies Act 1993*

*Company No.: 1723921*

I have concluded the liquidation of the above-named company and hereby give notice in accordance with section 318(1)(e)(i) of the Companies Act 1993.

I have filed my final report and consequently the company is to be removed from the Register.

Notice is given that unless written objection to the removal of the company is sent or delivered to the Registrar, pursuant to section 321 of the Act, within 20 working days, the Registrar may remove the company from the Register.

Dated at Christchurch this 7th day of February 2008.

RICHARD NICHOLAS INESON, Liquidator.

ds982

**Huntly Industries Limited** (in liquidation)

**Notice of Intention to Remove Company From the Register**

We, David Donald Crichton and Keiran Anne Horne, liquidators of the above-named company, hereby give notice that, pursuant to section 318(1)(e) of the Companies Act 1993 and having filed with the Registrar our final report on the liquidation, it is intended to remove the company from the New Zealand Register.

Any objection to the removal, pursuant to section 321 of the Companies Act 1993, must be delivered to the Registrar no later than 12 March 2008.

Dated this 12th day of February 2008.

K. A. HORNE, Liquidator.

ds997

**JJK Holdings Limited** (in liquidation)

**Notice of Intention to Remove Company From the Register**

We, David Donald Crichton and Keiran Anne Horne, liquidators of the above-named company, hereby give notice that, pursuant to section 318(1)(e) of the Companies Act 1993 and having filed with the Registrar our final report on the liquidation, it is intended to remove the company from the New Zealand Register.

Any objection to the removal, pursuant to section 321 of the Companies Act 1993, must be delivered to the Registrar no later than 12 March 2008.

Dated this 12th day of February 2008.

K. A. HORNE, Liquidator.

ds998

**Colmat Beef Limited** (in liquidation)

**Notice of Intention to Remove Company From the Register of Companies**

Notice is hereby given by the liquidator that, in accordance with section 318 of the Companies Act 1993, Colmat Beef Limited (in liquidation), whose registered office is situated at Ainger Tomlin Limited, Level 1, 116 Riccarton Road,

Christchurch, will be removed from the Register of Companies due to the completion of the liquidation.

Any objection, under section 321 of the Companies Act 1993, must be delivered to the Registrar before 28 March 2008.

MARK J. O'REILLY, Liquidator.

*Address for Service:* Ainger Tomlin Limited, Chartered Accountants, 1st Floor, 116 Riccarton Road (PO Box 8237), Christchurch. Telephone: (03) 343 0046. Facsimile: (03) 348 9312.

ds1135

**Major Jones Pool Fishing Lodge Limited** (in liquidation)

**Notice of Intention to Remove Company From the Register**

*Pursuant to Section 320 of the Companies Act 1993*

I, John David Naylor, liquidator of Major Jones Pool Fishing Lodge Limited, hereby give notice that, pursuant to section 318(1)(e) of the Companies Act 1993 and having filed with the Registrar my final report on the liquidation, it is intended to remove the company from the New Zealand Register.

Any objection to the removal, pursuant to section 321 of the Companies Act 1993, must be delivered to the Registrar no later than 12 March 2008.

Dated this 12th day of February 2008.

J. D. NAYLOR, Liquidator, Major Jones Pool Fishing Lodge Limited (in liquidation).

ds1003

**Grenada Produce VI Limited** (in liquidation)

**Notice of Intention to Remove Company From the Register**

*Pursuant to Section 320(2) of the Companies Act 1993*

Notice is given that it is intended to remove from the New Zealand Register Grenada Produce VI Limited ("the company"), which has its registered office at 139 Moray Place, Dunedin, by request, under section 318(1)(e) of the Companies Act 1993 ("the Act"), on the grounds that the company has ceased to carry on business, has discharged in full its liabilities to all known creditors, and has distributed its surplus assets in accordance with its constitution and the Act.

The date by which an objection to the removal, under section 321 of the Act, must be delivered to the Registrar is 20 March 2008.

Dated this 13th day of February 2008.

H. M. VAN DYK, Liquidator.

ds1036

**Elysian Holdings Limited** (in liquidation)

**Notice of Intention to Remove Company From the Register**

Public notice is given that, pursuant to section 318(1)(e) of the Companies Act 1993, the Registrar must remove Elysian Holdings Limited (in liquidation), whose registered office is situated at Level 7, 44 Victoria Street, Wellington, from the New Zealand Register on the grounds that the documents referred to in section 257(1)(a) of the Companies Act 1993 have been sent or delivered to the Registrar of Companies, thereby completing the liquidation pursuant to section 249 of the Act.

Unless, pursuant to section 321 of the Act, written objection to the removal is delivered to the Registrar by 14 March 2008 (being a date not less than 20 working days after the

date of this notice), the Registrar is obliged to remove the company from the Register.

Dated this 15th day of February 2008.

R. B. HUDSON, Liquidator.

ds1074

### **Gleneagles Limited (in liquidation)**

#### **Notice of Intention to Remove Company From the Register**

Public notice is given that, pursuant to section 318(1)(e) of the Companies Act 1993, the Registrar must remove Gleneagles Limited (in liquidation), whose registered office is situated at Level 7, 44 Victoria Street, Wellington, from the New Zealand Register on the grounds that the documents referred to in section 257(1)(a) of the Companies Act 1993 have been sent or delivered to the Registrar of Companies, thereby completing the liquidation pursuant to section 249 of the Act.

Unless, pursuant to section 321 of the Act, written objection to the removal is delivered to the Registrar by 14 March 2008 (being a date not less than 20 working days after the date of this notice), the Registrar is obliged to remove the company from the Register.

Dated this 15th day of February 2008.

R. B. HUDSON, Liquidator.

ds1073

### **Ordinum Limited (in liquidation)**

#### **Notice of Intention to Remove Company From the Register**

Public notice is given that, pursuant to section 318(1)(e) of the Companies Act 1993, the Registrar must remove Ordinum Limited (in liquidation), whose registered office is situated at Level 7, 44 Victoria Street, Wellington, from the New Zealand Register on the grounds that the documents referred to in section 257(1)(a) of the Companies Act 1993 have been sent or delivered to the Registrar of Companies, thereby completing the liquidation pursuant to section 249 of the Act.

Unless, pursuant to section 321 of the Act, written objection to the removal is delivered to the Registrar by 14 March 2008 (being a date not less than 20 working days after the date of this notice), the Registrar is obliged to remove the company from the Register.

Dated this 15th day of February 2008.

R. B. HUDSON, Liquidator.

ds1072

### **Toscanus Limited (in liquidation)**

#### **Notice of Intention to Remove Company From the Register**

Public notice is given that, pursuant to section 318(1)(e) of the Companies Act 1993, the Registrar must remove Toscanus Limited (in liquidation), whose registered office is situated at Level 7, 44 Victoria Street, Wellington, from the New Zealand Register on the grounds that the documents referred to in section 257(1)(a) of the Companies Act 1993 have been sent or delivered to the Registrar of Companies, thereby completing the liquidation pursuant to section 249 of the Act.

Unless, pursuant to section 321 of the Act, written objection to the removal is delivered to the Registrar by 14 March 2008 (being a date not less than 20 working days after the date of this notice), the Registrar is obliged to remove the company from the Register.

Dated this 15th day of February 2008.

R. B. HUDSON, Liquidator.

ds1071

### **G & M Cocks Limited (in liquidation)**

#### **Notice of Intention to Apply for Removal of the Above-named Company From the Register**

*Pursuant to Section 320(2) of the Companies Act 1993*

*Company No.: 1566433*

I have concluded the liquidation of G & M Cocks Limited and hereby give notice in accordance with section 318(1)(e)(i) of the Companies Act 1993.

I have filed my final report and consequently the company is to be removed from the Register.

Notice is given that unless written objection to the removal of the company is sent or delivered to the Registrar, pursuant to section 321 of the Act, by 25 March 2008, the Registrar may remove the company from the Register.

Dated at Ashburton this 11th day of February 2008.

TREVOR J. CROY F.C.A., A.C.I.S., Liquidator.

ds1055

### **Kangaloolah Pty Limited (in liquidation)**

#### **Notice of Intention to Remove Company From the Register**

*Company No.: 1119079*

Notice is hereby given that the liquidator's final report has been delivered to the Registrar and that it is now intended to remove the company from the New Zealand Register, under section 318(1)(e) of the Companies Act 1993, on the grounds that the company has ceased to carry on business, has discharged in full its liabilities to all its known creditors, and has distributed its surplus assets in accordance with its constitution and the Companies Act 1993.

Notice is given that unless written objection to the removal of the company is sent or delivered to the Registrar, pursuant to section 321 of the Act, by 17 March 2008, the Registrar may remove the company from the Register.

Dated at Christchurch this 15th day of February 2008.

A. M. OORSCHOT, Liquidator.

ds1093

### **St Aubyns Limited (in liquidation)**

#### **Notice of Intended Removal of the Company From the Register**

Notice is hereby given that I, the undersigned liquidator of St Aubyns Limited (in liquidation), whose registered office is situated at 109–113 Powderham Street, New Plymouth, intend to deliver to the Registrar of Companies the final reports and statements referred to in section 257(1)(a) of the Companies Act 1993 with the intent that the company be removed from the New Zealand Register, pursuant to section 318(1)(e) of the Companies Act 1993, on the grounds that the liquidation of the company has been completed.

Unless written objection to such removal, under section 321 of the Act, is delivered to the Registrar of Companies at Auckland by 28 March 2008 (being a date not less than 20 working days after the date of this notice), the Registrar may remove the company from the Register.

Dated this 13th day of February 2008.

BRUCE CARLAW RICHARDS, Liquidator.

ds1025

**Redstock Properties Limited (in liquidation)****Notice of Intention to Apply for Removal of Company From the Register**

Notice is hereby given that the liquidator's final report has been delivered to the Registrar and it is now intended to remove the company from the New Zealand Register under section 318(1)(e) of the Companies Act 1993.

Any objections to the removal of the company, under section 321, must be delivered to the Registrar by 25 March 2008.

Dated at Christchurch this 18th day of February 2008.

GARTH MOORE, Liquidator.

*Address for Service:* Garth Moore Chartered Accountants, PO Box 30159, Christchurch.

ds1167

**CESSATION OF BUSINESS IN NEW ZEALAND****Austrade Holdings Pty Ltd****Notice by Overseas Company of Intention to Cease to Carry on Business in New Zealand**

*Pursuant to Section 341 of the Companies Act 1993*

Notice is hereby given that Austrade Holdings Pty Ltd ("the company"), an overseas company having its principal place of business in New Plymouth, intends to cease to carry on business in New Zealand and that a notice will be delivered to the Registrar of Companies, not earlier than three months after the date of this notice, of the company's intention to cease to carry on business in New Zealand on the grounds that, at the date of such request, the company will have ceased to carry on business in New Zealand.

Dated this 15th day of February 2008.

PETER ANGUS DANE, Director.

*Contact:* D. F. Crawley & Associates, Level 6, 105 St George's Terrace, Perth, Western Australia 6000.

cb1098

**IDC Technologies Pty Ltd****Notice of Intention to Cease Carrying on Business in New Zealand**

In the matter of the Companies Act 1993, and in the matter of IDC Technologies Pty Ltd:

Notice is hereby given, pursuant to section 341(1) of the Companies Act 1993, that IDC Technologies Pty Ltd, a company incorporated in Australia, intends to cease carrying on business in New Zealand.

Dated this 12th day of February 2008.

STEPHEN MACKAY, Director.

cb1001

**APPLICATIONS FOR WINDING UP / LIQUIDATIONS****Advertisement of Application for Putting Company into Liquidation**

CIV-2008-488-39

Take notice that on 23 January 2008, an application for putting **Sheppard Sawmills Limited** (now known as **Big Kerf Limited**) into liquidation by the High Court was filed in the High Court at Whangarei.

The application is to be heard before the High Court at Whangarei on Monday, 17 March 2008 at 10.00am.

Any person, other than the defendant company, who wishes to appear on the hearing of the application must file an appearance not later than the second working day before that date.

The plaintiff is **Accident Compensation Corporation**, whose address for service is at the offices of Maude & Miller, 2nd Floor, McDonald's Building, Cobham Court (PO Box 50555 or DX SP 32505), Porirua City.

Further particulars may be obtained from the office of the Court or from the plaintiff or the plaintiff's solicitor.

DIANNE S. LESTER, Solicitor for the Plaintiff.

aw1068

**Advertisement of Application for Putting Company into Liquidation**

CIV-2007-404-7149

Take notice that on 16 November 2007, an application for putting **Condor Freight Limited** into liquidation by the High Court was filed in the High Court at Auckland.

The application is to be heard before the High Court at Auckland on Wednesday, 9 April 2008 at 10.00am.

Any person, other than the defendant company, who wishes to appear on the hearing of the application must file an

appearance not later than the second working day before that date.

The plaintiff is **Accident Compensation Corporation**, whose address for service is at the offices of Maude & Miller, 2nd Floor, McDonald's Building, Cobham Court (PO Box 50555 or DX SP 32505), Porirua City.

Further particulars may be obtained from the office of the Court or from the plaintiff or the plaintiff's solicitor.

DIANNE S. LESTER, Solicitor for the Plaintiff.

aw1067

**Advertisement of Application for Putting Company into Liquidation**

CIV-2008-404-34

Take notice that on Monday, 7 January 2008, an application for putting **Central Builders Limited** into liquidation by the High Court was filed in the High Court at Auckland.

The application is to be heard before the High Court at Auckland on Wednesday, 12 March 2008 at 10.45am.

Any person, other than the defendant company, who wishes to appear on the hearing of the application must file an appearance not later than the second working day before that day.

The plaintiff is **Trends Aluminium 2000 Limited**, whose solicitor is Malcolm Whitlock, whose address for service is at the offices of Debt Recovery Group NZ Limited, Level 5, 5 Short Street, Newmarket, Auckland. *Postal Address:* PO Box 99675, Newmarket, Auckland.

Further particulars may be obtained from the office of the Court or from the plaintiff or the plaintiff's solicitor.

MALCOLM WHITLOCK, Solicitor for the Plaintiff.

aw972



### Advertisement of Application for Putting Company into Liquidation

CIV-2007-404-7945

Take notice that on 18 December 2007, an application for putting **Cleary Wealth Management Limited** into liquidation by the High Court was filed in the High Court at Auckland.

The application is to be heard before the High Court at Auckland on Friday, 9 May 2008 at 10.00am.

Any person, other than the defendant company, who wishes to appear on the hearing of the application must file an appearance not later than the second working day before that day.

The plaintiff is **Exception Interiors Limited**, whose address for service is at the offices of Morgan Coakle, Solicitors, Level 12, 51-53 Shortland Street, Auckland.

Further particulars may be obtained from the office of the Court or from the plaintiff's solicitor.

K. A. MUIR, Solicitor for the Plaintiff.

aw996

### Advertisement of Application for Putting Company into Liquidation

CIV-2007-404-7724

Take notice that on 10 December 2007, an application for putting **Ned Kelly Building Supplies (2003) Limited** into liquidation by the High Court was filed in the High Court at Auckland.

The application is to be heard before the High Court at Auckland on 11 April 2008 at 10.45am.

Any person, other than the defendant company, who wishes to appear on the hearing of the application must file an appearance not later than the second working day before that date.

The plaintiff is **Nationwide Prehung Doors Limited**, whose address for service is at the offices of its solicitors, Fortune Manning, gen-i Tower, Level 12, 66 Wyndham Street (PO Box 4139), Auckland.

Further particulars may be obtained from the office of the Court or from the plaintiff or the plaintiff's solicitor.

M. M. EDWARDS, Solicitor for the Plaintiff.

aw1028

### Advertisement of Application for Putting Company into Liquidation

Take notice that on 30 January 2008, an application for putting **Policy Factoring Limited** (in receivership) into liquidation by the High Court was filed in the High Court at Auckland.

The application is to be heard before the High Court at Auckland on Thursday, 6 March 2008 at 10.45am.

Any person, other than the defendant company, who wishes to appear on the hearing of the application must file an appearance not later than the second working day before that day.

The plaintiff is **White Heron Motor Lodge Limited**, whose address for service is the offices of Willis Toomey Robinson, 116 Vautier Street (Private Bag 6018), Napier. Facsimile: (06) 835 1430.

Further particulars may be obtained from the office of the Court or from the plaintiff or the plaintiff's solicitor.

M. J. WENLEY, Solicitor for the Plaintiff.

aw1154

### Advertisement of Application for Putting Company into Liquidation

Take notice that on 11 December 2007, an application for putting **New Zealand Protective Coatings Wellington Limited** into liquidation by the High Court was filed in the High Court at Wellington.

The application is to be heard before the High Court at Wellington on 3 March 2008 at 10.00am.

Any person, other than the defendant company, who wishes to appear on the hearing of the application must file an appearance not later than the second working day before that day.

The plaintiff is **Kaiwharawhara Trading Limited**, whose address for service is care of the offices of Collins & May Law Office, 4th Floor, 44 Queens Drive (PO Box 30614), Lower Hutt. Telephone: (04) 566 5775.

Further particulars may be obtained from the office of the Court or from the plaintiff or the plaintiff's solicitor.

E. J. COLLINS, Solicitor for the Plaintiff.

aw1171

### Advertisement of Application for Putting Company into Liquidation

CIV-2007-404-6222

Take notice that on 5 October 2007, an application for putting **K Road 340 Limited** into liquidation by the High Court was filed in the High Court at Auckland.

The application is to be heard before the High Court at Auckland on Thursday, 6 March 2008 at 10.00am.

Any person, other than the defendant company, who wishes to appear on the hearing of the application must file an appearance not later than the second working day before that day.

The plaintiff is **Bayleys Real Estate Limited**, whose address for service is at the offices of Corporate Collections Limited, 187 Mt Eden Road, Mt Eden, Auckland.

Further particulars may be obtained from the office of the Court or from the plaintiff or the plaintiff's solicitor.

C. N. LORD, Solicitor for the Plaintiff.

aw1144

### Advertisement of Application for Putting Company into Liquidation by the Court

CIV-2007-404-5539

Take notice that on 3 September 2007, an application for putting **Black Light Publishing Limited** into liquidation by the High Court was filed in the High Court at Auckland.

The application is to be heard before the High Court at Auckland on 6 March 2008 at 10.00am.

Any person, other than the defendant company, who wishes to appear on the hearing of the application must file an appearance not later than the second working day before that day.

The plaintiff is **Blue Star Print Group (New Zealand) Limited** (trading as **McCollams**), whose address for service is at the offices of Whitlock & Co., c/o Level 2, Baycorp House, 15 Hopetoun Street, Auckland.

Further particulars may be obtained from the office of the Court or from the plaintiff or the plaintiff's solicitor.

MALCOLM DAVID WHITLOCK, Solicitor for the Plaintiff.

aw1119

### Advertisement of Application for Putting Company into Liquidation by the Court

CIV-2008-463-2

Take notice that on 8 January 2008, an application for putting **Designakit Buildings Limited** into liquidation by the High Court was filed in the High Court at Rotorua.

The application is to be heard before the High Court at Rotorua on 10 March 2008 at 10.45am.

Any person, other than the defendant company, who wishes to appear on the hearing of the application must file an appearance not later than the second working day before that day.

The plaintiff is **B J Moss Limited**, whose address for service is at the offices of Whitlock & Co., c/o Level 2, Baycorp House, 15 Hopetoun Street, Auckland.

Further particulars may be obtained from the office of the Court or from the plaintiff or the plaintiff's solicitor.

MALCOLM DAVID WHITLOCK, Solicitor for the Plaintiff.  
aw1117

### Advertisement of Application for Putting Company into Liquidation

CIV-2008-485-72

Take notice that on 15 January 2008, an application for putting **Win-Dey Construction Limited** into liquidation by the High Court was filed in the High Court at Wellington.

The application is to be heard before the High Court at Wellington on 3 March 2008 at 10.00am.

Any person other than the defendant company who wishes to appear on the hearing of the application must file an appearance not later than the second working day before that day.

The plaintiff is **Gas Pro Plumbing Limited**, whose address for service is at the offices of Thomas Dewar Sziranyi Letts, Solicitors, 2nd Floor, 1 Margaret Street (PO Box 31240), Lower Hutt (*Solicitor Acting: Matt Freeman*).

Further particulars may be obtained from the office of the Court or from the plaintiff or the plaintiff's solicitor.

D. G. DEWAR, Solicitor for the Plaintiff.  
aw1046

### Advertisement of Application for Putting Company into Liquidation

Take notice that on 24 January 2008, an application for putting **Central Otago House Limited** into liquidation by the High Court was filed in the High Court at Dunedin.

The application is to be heard before the High Court at Dunedin on Thursday, 27 March 2008 at 10.00am.

Any person, other than the defendant company, who wishes to appear on the hearing of the application must file an appearance not later than the second working day before that day.

The plaintiff is **Fulton Hogan Limited**, a duly incorporated company having its registered office at 11 Main Road, Fairfield, Dunedin, whose address for service is at the offices of Russell Cassidy, Lawyer, 3rd Floor, corner of Moray Place and Princes Street, Dunedin.

Further particulars may be obtained from the office of the Court or from the plaintiff or the plaintiff's solicitor.

R. J. CASSIDY, Solicitor for the Plaintiff.  
aw1132

### Advertisement of Application for Putting Company into Liquidation

CIV-2007-404-5654

Take notice that on 10 September 2007, an application for putting **Phoenix Linnings Limited** into liquidation by the High Court was filed in the High Court at Auckland.

The application is to be heard before the High Court at Auckland on Thursday, 13 March 2008 at 10.00am.

Any person, other than the defendant company, who wishes to appear on the hearing of the application must file an appearance not later than the second working day before that day.

The plaintiff is the **Commissioner of Inland Revenue**, whose address for service is Inland Revenue Department, Legal and Technical Services, 5-7 Byron Avenue (PO Box 33150), Takapuna, Auckland. Telephone: (09) 984 1309. Facsimile: (09) 984 3116.

Further particulars may be obtained from the office of the Court or from the plaintiff's solicitor, Kathleena Hemotitaha Smith, contact details as noted above.

KATHLEENA HEMOTITAHA SMITH, Solicitor for the Plaintiff.  
aw1087

### Advertisement of Application for Putting Company into Liquidation

CIV-2008-404-56

Take notice that on 9 January 2008, an application for putting **The Apparel Index Limited** into liquidation by the High Court was filed in the High Court at Auckland.

The application is to be heard before the High Court at Auckland on Wednesday, 12 March 2008 at 10.45am.

Any person, other than the defendant company, who wishes to appear on the hearing of the application must file an appearance not later than the second working day before that day.

The plaintiff is the **Commissioner of Inland Revenue**, whose address for service is Inland Revenue Department, Legal and Technical Services, 5-7 Byron Avenue (PO Box 33150), Takapuna, Auckland. Telephone: (09) 984 1514. Facsimile: (09) 984 3116.

Further particulars may be obtained from the office of the Court or from the plaintiff's solicitor, Michael Kinlim Yan, contact details as noted above.

MICHAEL KINLIM YAN, Solicitor for the Plaintiff.  
aw1054

### Advertisement of Application for Putting Company into Liquidation

Take notice that on 24 October 2007, an application for putting **Auckland Coating Systems Limited** into liquidation by the High Court was filed in the High Court at Auckland.

The application is to be heard before the High Court at Auckland on Thursday, 6 March 2008 at 10.00am.

Any person, other than the defendant company, who wishes to appear on the hearing of the application must file an appearance not later than the second working day before that day.

The plaintiff is the **Commissioner of Inland Revenue**, whose address for service is Simon John Eisdell Moore, Crown Solicitor, at the offices of Meredith Connell, Level 17, Forsyth Barr Tower, 55-65 Shortland Street (PO Box 2213 or DX CP 24063), Auckland (*Enquiries to: R. E. Harvey on telephone (09) 336 7556*).

Further particulars may be obtained from the office of the Court or from the plaintiff or the plaintiff's solicitor.

S. J. EISDELL MOORE, Solicitor for the Plaintiff.

aw1079

### Advertisement of Application for Putting Company into Liquidation

Take notice that on 24 October 2007, an application for putting **S M Surfboards Limited** into liquidation by the High Court was filed in the High Court at Auckland.

The application is to be heard before the High Court at Auckland on Thursday, 6 March 2008 at 10.45am.

Any person, other than the defendant company, who wishes to appear on the hearing of the application must file an appearance not later than the second working day before that day.

The plaintiff is the **Commissioner of Inland Revenue**, whose address for service is Simon John Eisdell Moore, Crown Solicitor, at the offices of Meredith Connell, Level 17, Forsyth Barr Tower, 55–65 Shortland Street (PO Box 2213 or DX CP 24063), Auckland (*Enquiries to:* R. E. Harvey on telephone (09) 336 7556).

Further particulars may be obtained from the office of the Court or from the plaintiff or the plaintiff's solicitor.

S. J. EISDELL MOORE, Solicitor for the Plaintiff.

aw1077

### Advertisement of Application for Putting Company into Liquidation

Take notice that on 29 October 2007, an application for putting **Action Business Solutions Limited** into liquidation by the High Court was filed in the High Court at Auckland.

The application is to be heard before the High Court at Auckland on Thursday, 6 March 2008 at 10.45am.

Any person, other than the defendant company, who wishes to appear on the hearing of the application must file an appearance not later than the second working day before that day.

The plaintiff is the **Commissioner of Inland Revenue**, whose address for service is Simon John Eisdell Moore, Crown Solicitor, at the offices of Meredith Connell, Level 17, Forsyth Barr Tower, 55–65 Shortland Street (PO Box 2213 or DX CP 24063), Auckland (*Enquiries to:* R. E. Harvey on telephone (09) 336 7556).

Further particulars may be obtained from the office of the Court or from the plaintiff or the plaintiff's solicitor.

S. J. EISDELL MOORE, Solicitor for the Plaintiff.

aw1080

### Advertisement of Application for Putting Company into Liquidation

Take notice that on 29 October 2007, an application for putting **Global Strategy Managers Limited** into liquidation by the High Court was filed in the High Court at Auckland.

The application is to be heard before the High Court at Auckland on Thursday, 6 March 2008 at 10.45am.

Any person, other than the defendant company, who wishes to appear on the hearing of the application must file an appearance not later than the second working day before that day.

The plaintiff is the **Commissioner of Inland Revenue**, whose address for service is Simon John Eisdell Moore, Crown Solicitor, at the offices of Meredith Connell, Level 17, Forsyth Barr Tower, 55–65 Shortland Street (PO Box 2213

or DX CP 24063), Auckland (*Enquiries to:* R. E. Harvey on telephone (09) 336 7556).

Further particulars may be obtained from the office of the Court or from the plaintiff or the plaintiff's solicitor.

S. J. EISDELL MOORE, Solicitor for the Plaintiff.

aw1078

### Advertisement of Application for Putting Company into Liquidation

CIV-2008-488-14

Take notice that on 24 January 2008, an application for putting **T Edgecombe Horticulture Limited** into liquidation by the High Court was filed in the High Court at Whangarei.

The application is to be heard before the High Court at Whangarei on Monday, 17 March 2008 at 10.00am.

Any person, other than the defendant company, who wishes to appear on the hearing of the application must file an appearance not later than the second working day before that day.

The plaintiff is the **Commissioner of Inland Revenue**, whose address for service is Inland Revenue Department, Legal and Technical Services, 1 Bryce Street (PO Box 432), Hamilton. Telephone: (07) 959 0373. Facsimile: (07) 959 7614.

Further particulars may be obtained from the office of the Court or from the plaintiff by contacting H. Malthus on telephone (07) 959 0229 in the first instance or the plaintiff's solicitor, Kay S. Morgan, contact details as noted above.

KAY S. MORGAN, Solicitor for the Plaintiff.

aw1113

### Advertisement of Application for Putting Company into Liquidation

CIV-2007-404-6413

Take notice that on 15 October 2007, an application for putting **Michel's Patisserie NZ Limited** into liquidation by the High Court was filed in the High Court at Auckland.

The application is to be heard before the High Court at Auckland on Thursday, 6 March 2008 at 10.00am.

Any person, other than the defendant company, who wishes to appear on the hearing of the application must file an appearance not later than the second working day before that day.

The plaintiff is the **Commissioner of Inland Revenue**, whose address for service is Inland Revenue Department, Legal and Technical Services, 1 Bryce Street (PO Box 432), Hamilton. Telephone: (07) 959 0373. Facsimile: (07) 959 7614.

Further particulars may be obtained from the office of the Court or from the plaintiff by contacting R. Illingworth on telephone (07) 959 0259 in the first instance or the plaintiff's solicitor, Kay S. Morgan, contact details as noted above.

KAY S. MORGAN, Solicitor for the Plaintiff.

aw1097

### Advertisement of Application for Putting Company into Liquidation

CIV-2007-404-7555

Take notice that on 3 December 2007, an application for putting **Computer Stuff Limited** into liquidation by the High Court was filed in the High Court at Auckland.

The application is to be heard before the High Court at Auckland on Friday, 18 April 2008 at 10.45am.



Any person, other than the defendant company, who wishes to appear on the hearing of the application must file an appearance not later than the second working day before that day.

The plaintiff is the **Commissioner of Inland Revenue**, whose address for service is Inland Revenue Department, Legal and Technical Services, 1 Bryce Street (PO Box 432), Hamilton. Telephone: (07) 959 0373. Facsimile: (07) 959 7614.

Further particulars may be obtained from the office of the Court or from the plaintiff by contacting R. A. Illingworth on telephone (07) 959 0259 in the first instance or the plaintiff's solicitor, Kay S. Morgan, contact details as noted above.

KAY S. MORGAN, Solicitor for the Plaintiff.

aw1152

### Advertisement of Application for Putting Company into Liquidation

CIV-2007-404-7605

Take notice that on 3 December 2007, an application for putting **Gutter Clean Limited** into liquidation by the High Court was filed in the High Court at Auckland.

The application is to be heard before the High Court at Auckland on Tuesday, 1 April 2008 at 10.45am.

Any person, other than the defendant company, who wishes to appear on the hearing of the application must file an appearance not later than the second working day before that day.

The plaintiff is the **Commissioner of Inland Revenue**, whose address for service is Inland Revenue Department, Legal and Technical Services, 1 Bryce Street (PO Box 432), Hamilton. Telephone: (07) 959 0373. Facsimile: (07) 959 7614.

Further particulars may be obtained from the office of the Court or from the plaintiff by contacting R. A. Illingworth on telephone (07) 959 0259 in the first instance or the plaintiff's solicitor, Kay S. Morgan, contact details as noted above.

KAY S. MORGAN, Solicitor for the Plaintiff.

aw1149

### Advertisement of Application for Putting Company into Liquidation

CIV-2007-404-7683

Take notice that on 7 December 2007, an application for putting **National Lining Limited** into liquidation by the High Court was filed in the High Court at Auckland.

The application is to be heard before the High Court at Auckland on Tuesday, 1 April 2008 at 10.45am.

Any person, other than the defendant company, who wishes to appear on the hearing of the application must file an appearance not later than the second working day before that day.

The plaintiff is the **Commissioner of Inland Revenue**, whose address for service is Inland Revenue Department, Legal and Technical Services, 1 Bryce Street (PO Box 432), Hamilton. Telephone: (07) 959 0373. Facsimile: (07) 959 7614.

Further particulars may be obtained from the office of the Court or from the plaintiff by contacting C. D. Astrella on telephone (07) 959 0225 in the first instance or the plaintiff's solicitor, Kay S. Morgan, contact details as noted above.

KAY S. MORGAN, Solicitor for the Plaintiff.

aw1150

### Advertisement of Application for Putting Company into Liquidation

CIV-2007-404-7705

Take notice that on 7 December 2007, an application for putting **Smartzone Co NZ Limited** into liquidation by the High Court was filed in the High Court at Auckland.

The application is to be heard before the High Court at Auckland on Friday, 18 April 2008 at 10.45am.

Any person, other than the defendant company, who wishes to appear on the hearing of the application must file an appearance not later than the second working day before that day.

The plaintiff is the **Commissioner of Inland Revenue**, whose address for service is Inland Revenue Department, Legal and Technical Services, 1 Bryce Street (PO Box 432), Hamilton. Telephone: (07) 959 0373. Facsimile: (07) 959 7614.

Further particulars may be obtained from the office of the Court or from the plaintiff by contacting C. D. Astrella on telephone (07) 959 0225 in the first instance or the plaintiff's solicitor, Kay S. Morgan, contact details as noted above.

KAY S. MORGAN, Solicitor for the Plaintiff.

aw1153

### Advertisement of Application for Putting Company into Liquidation

CIV-2008-404-55

Take notice that on 9 January 2008, an application for putting **AAA Parts and Auto Services Limited** into liquidation by the High Court was filed in the High Court at Auckland.

The application is to be heard before the High Court at Auckland on Wednesday, 12 March 2008 at 10.45am.

Any person, other than the defendant company, who wishes to appear on the hearing of the application must file an appearance not later than the second working day before that day.

The plaintiff is the **Commissioner of Inland Revenue**, whose address for service is Inland Revenue Department, Legal and Technical Services, 1 Bryce Street (PO Box 432), Hamilton. Telephone: (07) 959 0373. Facsimile: (07) 959 7614.

Further particulars may be obtained from the office of the Court or from the plaintiff by contacting C. D. Astrella on telephone (07) 959 0225 in the first instance or the plaintiff's solicitor, Kay S. Morgan, contact details as noted above.

KAY S. MORGAN, Solicitor for the Plaintiff.

aw1151

### Advertisement of Application for Putting Company into Liquidation

CIV-2008-485-60

Take notice that on 16 January 2008, an application for putting **Eleworks Consulting Limited** into liquidation by the High Court was filed in the High Court at Wellington.

The application is to be heard before the High Court at Wellington on Monday, 3 March 2008 at 10.00am.

Any person, other than the defendant company, who wishes to appear on the hearing of the application must file an appearance not later than the second working day before that day.

The plaintiff is the **Commissioner of Inland Revenue**, whose address for service is Inland Revenue Department, Legal and Technical Services, 1 Bryce Street (PO Box

432), Hamilton. Telephone: (07) 959 0373. Facsimile: (07) 959 7614.

Further particulars may be obtained from the office of the Court or from the plaintiff by contacting H. Malthus on telephone (07) 959 0229 in the first instance or the plaintiff's solicitor, Kay S. Morgan, contact details as noted above.

KAY S. MORGAN, Solicitor for the Plaintiff.

aw1108

### Advertisement of Application for Putting Company into Liquidation

CIV-2008-442-10

Take notice that on 16 January 2008, an application for putting **Tasman Cleaning Limited** into liquidation by the High Court was filed in the High Court at Nelson.

The application is to be heard before the High Court at Nelson on Wednesday, 12 March 2008 at 10.00am.

Any person, other than the defendant company, who wishes to appear on the hearing of the application must file an appearance not later than the second working day before that day.

The plaintiff is the **Commissioner of Inland Revenue**, whose address for service is Inland Revenue Department, Legal and Technical Services, 1 Bryce Street (PO Box 432), Hamilton. Telephone: (07) 959 0373. Facsimile: (07) 959 7614.

Further particulars may be obtained from the office of the Court or from the plaintiff by contacting H. Malthus on telephone (07) 959 0229 in the first instance or the plaintiff's solicitor, Kay S. Morgan, contact details as noted above.

KAY S. MORGAN, Solicitor for the Plaintiff.

aw1115

### Advertisement of Application for Putting Company into Liquidation

CIV-2008-442-40

Take notice that on 5 February 2008, an application for putting **Lloyd & Stevenson Limited** (formerly **Thug Enterprises Limited**) into liquidation by the High Court was filed in the High Court at Nelson.

The application is to be heard before the High Court at Nelson on Wednesday, 12 March 2008 at 10.00am.

Any person, other than the defendant company, who wishes to appear on the hearing of the application must file an appearance not later than the second working day before that day.

The plaintiff is the **Commissioner of Inland Revenue**, whose address for service is Inland Revenue Department, Legal and Technical Services, 1 Bryce Street (PO Box 432), Hamilton. Telephone: (07) 959 0373. Facsimile: (07) 959 7614.

Further particulars may be obtained from the office of the Court or from the plaintiff by contacting C. D. Astrella on telephone (07) 959 0225 in the first instance or the plaintiff's solicitor, Kay S. Morgan, contact details as noted above.

KAY S. MORGAN, Solicitor for the Plaintiff.

aw1110

### Advertisement of Application for Putting Company into Liquidation

CIV-2008-412-12

Take notice that on 16 January 2008, an application for putting **RSM New Zealand Pty Limited** into liquidation by the High Court was filed in the High Court at Dunedin.

The application is to be heard before the High Court at Dunedin on Thursday, 27 March 2008 at 10.00am.

Any person, other than the defendant company, who wishes to appear on the hearing of the application must file an appearance not later than the second working day before that day.

The plaintiff is the **Commissioner of Inland Revenue**, whose address for service is Inland Revenue Department, Legal and Technical Services, 1 Bryce Street (PO Box 432), Hamilton. Telephone: (07) 959 0373. Facsimile: (07) 959 7614.

Further particulars may be obtained from the office of the Court or from the plaintiff by contacting H. Malthus on telephone (07) 959 0229 in the first instance or the plaintiff's solicitor, Kay S. Morgan, contact details as noted above.

KAY S. MORGAN, Solicitor for the Plaintiff.

aw1111

### Advertisement of Application for Putting Company into Liquidation

CIV-2007-470-1067

Take notice that on 21 December 2007, an application for putting **Bay Mortgage and Insurance Consultants Limited** (formerly **Bar-Smith Associates Limited**) into liquidation by the High Court was filed in the High Court at Tauranga.

The application is to be heard before the High Court at Rotorua on Monday, 10 March 2008 at 10.45am.

Any person, other than the defendant company, who wishes to appear on the hearing of the application must file an appearance not later than the second working day before that day.

The plaintiff is the **Commissioner of Inland Revenue**, whose address for service is Inland Revenue Department, Legal and Technical Services, 1 Bryce Street (PO Box 432), Hamilton. Telephone: (07) 959 0416. Facsimile: (07) 959 7614.

Further particulars may be obtained from the office of the Court or from the plaintiff by contacting H. Malthus on telephone (07) 959 0229 in the first instance or the plaintiff's solicitor, R. L. Scott, contact details as noted above.

R. L. SCOTT, Solicitor for the Plaintiff.

aw1107

### Advertisement of Application for Putting Company into Liquidation

CIV-2007-470-1068

Take notice that on 21 December 2007, an application for putting **Tanner Properties Limited** into liquidation by the High Court was filed in the High Court at Tauranga.

The application is to be heard before the High Court at Rotorua on Monday, 10 March 2008 at 10.45am.

Any person, other than the defendant company, who wishes to appear on the hearing of the application must file an appearance not later than the second working day before that day.

The plaintiff is the **Commissioner of Inland Revenue**, whose address for service is Inland Revenue Department, Legal and Technical Services, 1 Bryce Street (PO Box 432), Hamilton. Telephone: (07) 959 0416. Facsimile: (07) 959 7614.

Further particulars may be obtained from the office of the Court or from the plaintiff by contacting H. Malthus on telephone (07) 959 0229 in the first instance or the plaintiff's solicitor, R. L. Scott, contact details as noted above.

R. L. SCOTT, Solicitor for the Plaintiff.

aw1114

### Advertisement of Application for Putting Company into Liquidation

CIV-2008-470-10

Take notice that on 8 January 2008, an application for putting **Solidpi Holdings Limited** into liquidation by the High Court was filed in the High Court at Tauranga.

The application is to be heard before the High Court at Rotorua on Monday, 10 March 2008 at 10.45am.

Any person, other than the defendant company, who wishes to appear on the hearing of the application must file an appearance not later than the second working day before that day.

The plaintiff is the **Commissioner of Inland Revenue**, whose address for service is Inland Revenue Department, Legal and Technical Services, 1 Bryce Street (PO Box 432), Hamilton. Telephone: (07) 959 0416. Facsimile: (07) 959 7614.

Further particulars may be obtained from the office of the Court or from the plaintiff by contacting C. D. Astrella on telephone (07) 959 0225 in the first instance or the plaintiff's solicitor, R. L. Scott, contact details as noted above.

R. L. SCOTT, Solicitor for the Plaintiff.

aw1106

### Advertisement of Application for Putting Company into Liquidation

CIV-2008-470-29

Take notice that on 16 January 2008, an application for putting **Ahchail Multicultural Limited** into liquidation by the High Court was filed in the High Court at Tauranga.

The application is to be heard before the High Court at Rotorua on Monday, 10 March 2008 at 10.45am.

Any person, other than the defendant company, who wishes to appear on the hearing of the application must file an appearance not later than the second working day before that day.

The plaintiff is the **Commissioner of Inland Revenue**, whose address for service is Inland Revenue Department, Legal and Technical Services, 1 Bryce Street (PO Box 432), Hamilton. Telephone: (07) 959 0416. Facsimile: (07) 959 7614.

Further particulars may be obtained from the office of the Court or from the plaintiff by contacting H. Malthus on telephone (07) 959 0229 in the first instance or the plaintiff's solicitor, R. L. Scott, contact details as noted above.

R. L. SCOTT, Solicitor for the Plaintiff.

aw1112

### Advertisement of Application for Putting Company into Liquidation

CIV-2008-463-7

Take notice that on 10 January 2008, an application for putting **Highclere Developments Limited** into liquidation by the High Court was filed in the High Court at Rotorua.

The application is to be heard before the High Court at Rotorua on Monday, 10 March 2008 at 10.45am.

Any person, other than the defendant company, who wishes to appear on the hearing of the application must file an appearance not later than the second working day before that day.

The plaintiff is the **Commissioner of Inland Revenue**, whose address for service is Inland Revenue Department, Legal and Technical Services, 1 Bryce Street (PO Box 432), Hamilton. Telephone: (07) 959 0416. Facsimile: (07) 959 7614.

Further particulars may be obtained from the office of the Court or from the plaintiff by contacting H. Malthus on telephone (07) 959 0229 in the first instance or the plaintiff's solicitor, R. L. Scott, contact details as noted above.

R. L. SCOTT, Solicitor for the Plaintiff.

aw1109

### Advertisement of Application for Putting Incorporated Society into Liquidation

CIV-2008-463-17

Take notice that on 15 January 2008, an application for putting **Te Korowai o Te Arohanoa Incorporated** (formerly **Te Korowai Aroha Mo Ngati Awa Incorporated**) into liquidation by the High Court was filed in the High Court at Rotorua.

The application is to be heard before the High Court at Rotorua on Monday, 10 March 2008 at 10.45am.

Any person, other than the defendant incorporated society, who wishes to appear on the hearing of the application must file an appearance not later than the second working day before that day.

The plaintiff is the **Commissioner of Inland Revenue**, whose address for service is Inland Revenue Department, Legal and Technical Services, 1 Bryce Street (PO Box 432), Hamilton. Telephone: (07) 959 0416. Facsimile: (07) 959 7614.

Further particulars may be obtained from the office of the Court or from the plaintiff by contacting H. Malthus on telephone (07) 959 0229 in the first instance or the plaintiff's solicitor, R. L. Scott, contact details as noted above.

R. L. SCOTT, Solicitor for the Plaintiff.

aw1116

### Advertisement of Application for Putting Company into Liquidation

CIV-2008-485-58

Take notice that on 16 January 2008, an application for putting **Les Jardins Du Pays Limited** into liquidation by the High Court was filed in the High Court at Wellington.

The application is to be heard before the High Court at Wellington on 3 March 2008 at 10.00am.

Any person, other than the defendant company, who wishes to appear on the hearing of the application must file an appearance not later than the second working day before that day.

The plaintiff is the **Commissioner of Inland Revenue**, whose address for service is Inland Revenue Department, Legal and Technical Services, 7-27 Waterloo Quay (PO Box 1462), Wellington. Telephone: (04) 890 1043. Facsimile: (04) 890 0009.

Further particulars may be obtained from the office of the Court or from the plaintiff's solicitor, Fiona Melanie Vining, contact details as noted above.

FIONA MELANIE VINING, Solicitor for the Plaintiff.

aw1081

### Advertisement of Application for Putting Company into Liquidation

CIV-2007-412-813

Take notice that on 25 September 2007, an application for putting **Wakatipu Naturally Limited** into liquidation by the High Court was filed in the High Court at Dunedin.

The application is to be heard before the High Court at Dunedin on 27 March 2008 at 10.00am.



Any person, other than the defendant company, who wishes to appear on the hearing of the application must file an appearance not later than the second working day before that day.

The plaintiff is the **Commissioner of Inland Revenue**, whose address for service is Inland Revenue Department, Legal and Technical Services, 7-27 Waterloo Quay (PO Box 1462), Wellington. Telephone: (04) 890 3281. Facsimile: (04) 890 0009.

Further particulars may be obtained from the office of the Court or from the plaintiff's solicitor, Catherine Ann Sweet, contact details as noted above.

CATHERINE ANN SWEET, Solicitor for the Plaintiff.

aw1020

### Advertisement of Application for Putting Company into Liquidation

CIV-2008-404-66

Take notice that on 7 January 2008, an application for putting **Planet Health 2003 Limited** into liquidation by the High Court was filed in the High Court at Auckland.

The application is to be heard before the High Court at Auckland on Wednesday, 12 March 2008 at 10.45am.

Any person, other than the defendant company, who wishes to appear on the hearing of the application must file an appearance not later than the second working day before that day.

The plaintiff is the **Commissioner of Inland Revenue**, whose address for service is Inland Revenue Department, Legal and Technical Services, First Floor Reception, 224 Cashel Street (PO Box 1782), Christchurch 8140. Telephone: (03) 968 0807. Facsimile: (03) 977 9853.

Further particulars may be obtained from the office of the Court or from the plaintiff's solicitor, Julie Newton, contact details as noted above.

JULIE NEWTON, Solicitor for the Plaintiff.

aw1022

### Advertisement of Application for Putting Company into Liquidation

CIV-2007-485-2613

Take notice that on 23 November 2007, an application for putting **On the Level Builders (06) Limited** into liquidation by the High Court was filed in the High Court at Wellington.

The application is to be heard before the High Court at Wellington on Monday, 3 March 2008 at 10.00am.

Any person, other than the defendant company, who wishes to appear on the hearing of the application must file an appearance not later than the second working day before that day.

The plaintiff is the **Commissioner of Inland Revenue**, whose address for service is Inland Revenue Department, Legal and Technical Services, First Floor Reception, 224 Cashel Street (PO Box 1782), Christchurch 8140. Telephone: (03) 968 0807. Facsimile: (03) 977 9853.

Further particulars may be obtained from the office of the Court or from the plaintiff's solicitor, Julie Newton, contact details as noted above.

JULIE NEWTON, Solicitor for the Plaintiff.

aw1070

### Advertisement of Application for Putting Company into Liquidation

CIV-2008-409-1

Take notice that on 4 January 2008, an application for putting **Lorraine Adams Design Limited** into liquidation

by the High Court was filed in the High Court at Christchurch.

The application is to be heard before the High Court at Christchurch on Monday, 3 March 2008 at 10.00am.

Any person, other than the defendant company, who wishes to appear on the hearing of the application must file an appearance not later than the second working day before that day.

The plaintiff is the **Commissioner of Inland Revenue**, whose address for service is Inland Revenue Department, Legal and Technical Services, First Floor Reception, 224 Cashel Street (PO Box 1782), Christchurch 8140. Telephone: (03) 968 0807. Facsimile: (03) 977 9853.

Further particulars may be obtained from the office of the Court or from the plaintiff's solicitor, Julie Newton, contact details as noted above.

JULIE NEWTON, Solicitor for the Plaintiff.

aw1130

### Advertisement of Application for Putting Company into Liquidation

CIV-2008-409-2

Take notice that on 4 January 2008, an application for putting **Suite Centre Limited** into liquidation by the High Court was filed in the High Court at Christchurch.

The application is to be heard before the High Court at Christchurch on Monday, 3 March 2008 at 10.00am.

Any person, other than the defendant company, who wishes to appear on the hearing of the application must file an appearance not later than the second working day before that day.

The plaintiff is the **Commissioner of Inland Revenue**, whose address for service is Inland Revenue Department, Legal and Technical Services, First Floor Reception, 224 Cashel Street (PO Box 1782), Christchurch 8140. Telephone: (03) 968 0807. Facsimile: (03) 977 9853.

Further particulars may be obtained from the office of the Court or from the plaintiff's solicitor, Julie Newton, contact details as noted above.

JULIE NEWTON, Solicitor for the Plaintiff.

aw1131

### Advertisement of Application for Putting Company into Liquidation

CIV-2007-412-1065

Take notice that on 24 December 2007, an application for putting **Wanaka Gas Limited** into liquidation by the High Court was filed in the High Court at Dunedin.

The application is to be heard before the High Court at Dunedin on Thursday, 27 March 2008 at 10.00am.

Any person, other than the defendant company, who wishes to appear on the hearing of the application must file an appearance not later than the second working day before that day.

The plaintiff is the **Commissioner of Inland Revenue**, whose address for service is Inland Revenue Department, Legal and Technical Services, First Floor Reception, 224 Cashel Street (PO Box 1782), Christchurch 8140. Telephone: (03) 968 0807. Facsimile: (03) 977 9853.

Further particulars may be obtained from the office of the Court or from the plaintiff's solicitor, Julie Newton, contact details as noted above.

JULIE NEWTON, Solicitor for the Plaintiff.

aw1094



## PARTNERSHIP NOTICES

### Certificate of Special Partnership

In the High Court of New Zealand, Auckland Registry

CIV-2008-404-6379

Under Part II of the Partnership Act 1908, and in the matter of **KAF Services Limited and Company** (operating as a dentistry business):

It is hereby certified, pursuant to section 51 of the Partnership Act 1908, that:

1. The name of the Special Partnership is **KAF Services Limited and Company**.
2. The names, addresses, occupations and capital contributions of the General Partner and Special Partner are set out in the Schedule.
3. The objects of the partnership are:
  - (a) to establish and carry on in Auckland and elsewhere the dentistry business set forth in the Schedule, and to undertake and carry out all other things which, in the opinion of the General Partner and the Special Partners, may be conveniently or profitably undertaken by the partnership, whether or not such things shall be similar in nature to the above object (the "partnership business");
  - (b) to engage in any other business or activity which, in the opinion of the General Partner and the Special Partners, may be conveniently or profitably undertaken by the partnership of whatsoever nature;
  - (c) to acquire, own, expand, develop, maintain, lease, take on hire, operate or hold for trade, with investments, manage, exchange, mortgage, sell or otherwise deal with or dispose of any real, personal, movable and immovable property of any description as well as tangible and intangible and without limiting the generality of the foregoing legal and equitable choses in action, policies of assurance or endowment, cash,

any active assets of a goodwill of any business or part thereof.

4. The principal place from which the partnership business will be conducted is the registered office of the General Partner.
5. The partnership shall commence upon registration of this certificate, pursuant to section 54 of the Partnership Act 1908 and, subject to the provisions in this deed of participation relating to earlier dissolution, shall terminate upon the expiry of seven years from the date of registration of this certificate.

### Schedule

#### General Partner

<i>Name and Address</i>	<i>Capital Contribution</i>
<b>KAF Services Limited</b> , Level 7, 45 Queen Street, Auckland 1010	NZ\$100.00

#### Execution Signed by:

ALAN FITZPATRICK, Director.

Acknowledged before me this 10th day of August 2006:

KIEU THI TRAN, J.P., 228 Monash Road, Tarrangindi, Queensland 4121, Australia.

#### Special Partner

<i>Name and Address</i>	<i>Capital Contribution</i>
<b>KAF Partners Limited</b> , Level 7, 45 Queen Street, Auckland 1010	NZ\$100.00

#### Execution Signed by:

ALAN FITZPATRICK, Director.

Acknowledged before me this 10th day of August 2006:

KIEU THI TRAN, J.P., 228 Monash Road, Tarrangindi, Queensland 4121, Australia.

pn1069

## OTHER

### Notice of Intention to Correct Register

I intend to rectify the New Zealand Register of companies and the Overseas Register, in terms of section 360A(1)(a) of the Companies Act 1993, on the application of the following companies by removing duplicate documents, deleting or replacing incorrect documents and, where applicable, entering new share totals or otherwise adjusting the Register. Dates are those of registration:

- AA Insurance Limited** (26389) – financial statements filed in error – 7 December 2007.
- Absolute CNC Limited** (1926432) – shares issued to A. W. Vallings on incorporation should have been issued to him and L. M. Holland jointly – 19 April 2007.
- ACM Insurance Brokers (Hamilton) Limited** (1763017) – incorrect constitution registered – 23 June 2006.
- EEC Properties Limited** (162280) – shares on reregistration and in constitution recorded as 5,000,000 instead of 3,213,275 – both 23 June 1997.
- Enadnum Limited** (1478854) – incorrect constitution registered – 15 February 2005.
- McDonald's Restaurants (New Zealand) Limited** (96461) – shares on reregistration recorded as 22,441,244 instead of 22,921,021 – 21 December 1995.
- Messagecom Pty Ltd** (2063522) – registered on the Overseas Register instead of incorporating a subsidiary in New Zealand – 27 November 2008 (registration to be cancelled).
- NZ Farming Systems Uruguay Limited** (1866126) – notice of issue of 74,513,296 shares should have been for 74,513,293 shares – 21 December 2007.
- NZFIT Limited** (1764473) – incorrect financial statements filed – 4 January 2008.
- Pathway Therapeutics Limited** (2020220) – notice of issue of 841,057 shares should have shown 21 January 2008 not 21 December 2007 as the date of issue – 30 January 2008.
- Patinaform Limited** (1988687) – incorrect constitution registered – 26 November 2007.

**Ponoko Limited** (1896161) – notices of issue of shares recorded 114,285 instead of 114,284 shares and 76,190 instead of 24,242 shares – 28 November 2007.

**Quayside Holdings Limited** (494708) – notice of issue of 9,000 shares duplicated earlier notice – 4 December 2007.

**RVNZ Limited** (1813797) – three notices of issue of shares omitted 4 shares – 12 November 2007 (2) and 5 December 2007.

**Sunridge Estate Limited** (1989169) – incorrect constitution registered – 26 September 2007.

**Surrey Trading Limited** (2058080) – incorrect constitution registered – 15 November 2007.

**Teviot Irrigation Company Limited** (445180) – reregistration application recorded incorrect number of shares – 22 July 1997.

**Waikite Apartments Limited** (11491) – incomplete constitution registered – 22 May 1998.

Any person who wishes to object must do so by 20 March 2008 (being not less than 20 working days after the date of this notice).

Dated this 21st day of February 2008.

NEVILLE HARRIS, Registrar of Companies.

Contact for Enquiries: 0508 COMPANIES (0508 266 726).

Postal Address for Written Objections: The Registrar of Companies, Private Bag 92061, Auckland Mail Centre.

Facsimile No. for Written Objections: (09) 916 4559.

ot1155

### Notice Prohibiting Person From Managing Companies

#### Pursuant to Section 385 of the Companies Act 1993

To: **Anthony James Elisara**.

Of: 120 Valley Road, Mt Maunganui.

Pursuant to section 385(3) of the Companies Act 1993, I, Peter Barker, Deputy Registrar of Companies, hereby prohibit **Anthony James Elisara** from being a director or promoter of, or being concerned in, or taking part, whether directly or indirectly, in the management of any company for a period of four years as from the date of this notice.

Dated at Wellington this 19th day of January 2008.

PETER BARKER, Deputy Registrar of Companies.

ot981

### Notice Prohibiting Person From Managing Companies

#### Pursuant to Section 385 of the Companies Act 1993

To: **Peter Louis Chevin**.

Of: 11 Maui Grove, Newmarket, Auckland.

Pursuant to section 385(3) of the Companies Act 1993, I, Peter Barker, Deputy Registrar of Companies, hereby prohibit **Peter Louis Chevin** from being a director or promoter of, or being concerned in, or taking part, whether directly or indirectly, in the management of any company for a period of four years as from the date of this notice.

Dated at Wellington this 8th day of February 2008.

PETER BARKER, Deputy Registrar of Companies.

ot1021

## Land Transfer Act / Joint Family Homes Act Notices

### Land Transfer Act Notice

The applicants described below have applied, under section 70 of the Land Transfer Act 1952, for the removal of a right of way. The applicants claim the right of way is redundant by reason of the circumstances set out below. I intend to remove the right of way on 25 March 2008, if no objections have been received before that date.

Application: 7704297.2.

Applicants: Robert James Knapstein and Alice Ie Tju Knapstein, Remuera, Auckland.

Easement: Right of way over Lot 1 DP 64354 (Composite Computer Registers NA47B/97–NA47B/100) coloured yellow on DP 64354 and Lot 1 DP 152820 (Composite Computer Registers NA93D/715, NA92A/641–NA92A/643); marked “A” on DP 152820 appurtenant to Lot 2 DP 152820 (Computer Freehold Register NA99C/454).

Circumstances: The dominant tenement has become physically separated from the servient tenements as a result of subdivision shown on DP 152820.

Dated at the Christchurch Office of Land Information New Zealand this 18th day of February 2008.

H. E. FRISBY, for Registrar General of Land.

lt1133

### Land Transfer Act Notice

I hereby give notice of an application lodged with me for the issue of a Computer Freehold Register to the below-named applicants, under section 19 of the Land Transfer Act 1952, for the land described below. Such Computer Freehold Register may be issued unless caveat forbidding the same is lodged on or before 21 April 2008.



*Application:* 7642062.1.

*Applicants:* Ralph Bradley Allen and Jostina Alida Riedstra, at Dunedin.

*Description:* An estate in fee simple in 6412 square metres, being Lot 1 DP 388030 on a plan lodged for deposit in the Otago Land District under LT 388030, being part Sections 16 and 17 Block IX North Harbour and Blueskin Survey District, which is the residue of the land remaining in Deeds Index L604.

Dated at the Christchurch Office of Land Information New Zealand this 13th day of February 2008.

JENNY SKERTEN, for Registrar-General of Land.

lt1123

## General Notices

### Notice of Entry into Possession of Mortgaged Property

#### Pursuant to Sections 137, 139 and 156 of the Property Law Act 2007

Notice is hereby given that **Advanced Securities Limited**, as mortgagee under mortgage 7309322.5 (“the mortgagee”) over the property located at **94B Mellons Bay Road, Howick, Auckland**, contained and described in Computer Freehold Register NA696/355 (North Auckland District) (“the property”), entered into physical possession of the property on **15 February 2008**.

This notice is given by the solicitors for the mortgagee, whose address for service is at the offices of Harkness Henry & Co, Solicitors, 7th/8th Floors, KPMG Centre, 85 Alexandra Street, Hamilton.

All communications relating to the properties should be:

- (a) posted to the solicitor at Harkness Henry & Co., Solicitors, Private Bag 3077, Hamilton; or
- (b) transmitted to the solicitor by facsimile to Harkness Henry & Co., Solicitors, on (07) 839 4043.

Dated at Hamilton this 15th day of February 2008.

Signed by Advanced Securities Limited by its solicitors and duly authorised agents Harkness Henry & Co:

KEVIN IAN BOND.

gn1122

### Notice of Entry into Possession of Mortgaged Property

#### Pursuant to Sections 137, 139 and 156 of the Property Law Act 2007

Notice is hereby given that **PMIT Nominees Limited**, as mortgagee under mortgage 7308770.3 (“the mortgagee”) over the property located at **2/96 Mellons Bay Road, Howick, Auckland**, contained and described in Computer Freehold Register NA122C/395 (North Auckland District) (“the property”), pursuant to an order of the Court, entered into physical possession of the property on **15 February 2008**.

This notice is given by the solicitors for the mortgagee, whose address for service is at the offices of Harkness Henry & Co, Solicitors, 7th/8th Floors, KPMG Centre, 85 Alexandra Street, Hamilton.

All communications relating to the properties should be:

- (a) posted to the solicitor at Harkness Henry & Co., Solicitors, Private Bag 3077, Hamilton; or
- (b) transmitted to the solicitor by facsimile to Harkness Henry & Co., Solicitors, on (07) 839 4043.

Dated at Hamilton this 15th day of February 2008.

Signed by PMIT Nominees Limited by its solicitors and duly authorised agents Harkness Henry & Co:

KEVIN IAN BOND.

gn1121

### Alliance Australia Claim Services Limited (formerly Switzerland Insurance Australia Limited)

#### Proposed Release of Deposit

*Pursuant to the Insurance Companies' Deposits Act 1953*

Alliance Australia Claim Services Limited (“the company”) has given notice to Public Trust that it has ceased to carry on the business of insurance in New Zealand and that it proposes to withdraw, pursuant to section 19 of the Act, the deposit which has been made by it with Public Trust.

Public Trust therefore gives notice, pursuant to section 19(3) of the Act, that, being satisfied that all liabilities of the company in New Zealand in respect of such insurance business have been fully liquidated or provided for, it proposes to release to the company on or after 25 March 2008, the amount deposited by the company.

Any objections to the release of the amount deposited should be lodged with Public Trust, 141 Willis Street, Wellington 6011, on or before 14 March 2008.

Dated at Wellington this 12th day of February 2008.

P. G. DYER, Public Trust.

gn1023

### Unclaimed Property

#### Notice of Election to Manage Property

Pursuant to section 101(1) of the Public Trust Act 2001, Public Trust hereby gives notice that:

- (a) **Georgeanna Janet Grace Tancred**, of London, United Kingdom, widow, who died at London, United Kingdom on or about 10 January 1913, is the owner of the property described in the Schedule hereto.
- (b) Public Trust elects to become manager of the property, it being satisfied that it is advisable in terms of section 101(1) of the above Act.

#### Schedule

A right of way strip at 89 Tuam Street, Christchurch, being an estate in fee simple containing 246 square metres (part Computer Freehold Register 164/84) (Canterbury Registry).

Dated at Christchurch this 21st day of December 2007.

R. J. CALVERT, Authorised Signatory.

gn112

---

## Departmental Notices

---

### Crown Law Office

---

#### Crown Solicitors Regulations 1994

---

##### Appointment of Crown Solicitor

His Excellency the Governor-General of New Zealand has been pleased to appoint

Grant John Burston, solicitor of Wellington

to be Crown Solicitor at Wellington, to take effect on 11 February 2008.

Dated at Wellington this 8th day of February 2008.

HON DR MICHAEL CULLEN, Attorney-General.

go1027

---



---

## Economic Development

---

### Crown Entities Act 2004

---

#### Appointment/reappointment to the New Zealand Trade and Enterprise Board

Pursuant to clause 28(3)(a) of the Crown Entities Act 2004, the Minister for Economic Development and the Minister of Trade have been pleased to appoint

Jon Mayson, of Tauranga

as a member of the New Zealand Trade and Enterprise Board for three years from 20 February 2008, and also as

chairman from 1 April 2008, with these appointments expiring on 19 February 2011; and reappoint

Craig Ellison, of Wellington

as a member of the New Zealand Trade and Enterprise Board for 12 months from 1 April 2008.

Dated at Wellington this 18th day of February 2008.

HON PETE HODGSON, Minister for Economic Development.

HON PHIL GOFF, Minister of Trade.

go1220

---



---

## Dumping and Countervailing Duties Act 1988

---

### 2007 Reassessment of Anti-dumping Duty: Canned Peaches from South Africa

Pursuant to section 14 of the Dumping and Countervailing Duties Act 1988 (“the Act”), the Minister of Commerce, having carried out a reassessment of the anti-dumping duty applying to imports into New Zealand of canned peaches from South Africa and having determined new amounts of anti-dumping duty applicable to those goods, gives the following notice.

#### Notice

**Title and commencement**—(1) This notice may be cited as the “2007 Reassessment of Anti-dumping Duty: Canned Peaches from South Africa”.

(2) This notice replaces and supersedes all previous notices in relation to the subject goods described below in the First Schedule.

(3) Pursuant to section 17 of the Act, the reassessed anti-dumping duty, set out in the Second Schedule to this notice, shall apply to imports of the goods specified in the First Schedule with effect from the day after the date of this notice.

(4) Where the anti-dumping duties imposed as a result of this notice are lower than those previously in place, in accordance with subsection 14(10) of the Act, importers may apply to Customs for a refund of the difference between the anti-dumping duties imposed by this notice and the anti-dumping duty paid from 31 May 2007.

#### Schedules

##### First Schedule

##### Subject Goods

The subject goods that the reassessed anti-dumping duties apply to are described as:

“Canned peaches (halves, slices or pieces) packed in various concentrations of sugar syrup and in can sizes ranging from 110 grams to 3 kilograms (A10)”

The goods are currently classified under Tariff Item and Statistical Key 2008.70.09.00L of the Tariff of New Zealand, which classification is provided for convenience and Customs purposes only, the written description being dispositive.

##### Second Schedule

##### Amount of Anti-dumping Duty

The amount of anti-dumping duty to be paid on demand in respect of each importation of the subject goods imported, or intended to be imported, into New Zealand from South Africa, shall be the amount by which the Non-Injurious Free on Board (NIFOB) or Normal Value (Value for Duty Equivalent) (NV(VFDE)) amounts set out below exceed the New Zealand Value for Duty of the goods when entered for home consumption.

**Normal Value (Value for Duty Equivalent) and Non-Injurious Free on Board Amounts Per Kilogram***(All non-confidential amounts in this notice are in South African rand)*

Product type and size	Imports from Langeberg & Ashton Foods Ltd by Brooke Holdings Ltd		Imports from Langeberg & Ashton Foods Ltd by other importers		Imports from Del Monte South Africa (Pty) Ltd		Imports from other Suppliers <sup>3</sup>	
	Choice	Sub-std	Choice	Sub-std	Choice	Sub-std	Choice	Sub-std
410gm <sup>4</sup>	1	8.65	12.07	8.65	1	8.75	12.21	8.75
825gm <sup>4</sup>	9.91	7.11	9.91	7.11	10.02	7.19	10.02	7.19
3kg <sup>4</sup>	1	7.01	9.78	7.01	9.89	7.09	9.89	7.09
Alternative Duty Rates <sup>2</sup> :								
410gm	12.07	–	–	–	12.21	–	–	–
825gm	–	–	–	–	–	–	–	–
3kg	9.78	–	–	–	–	–	–	–

<sup>1</sup>Non-Injurious Free On Board amounts have been kept confidential as they are based on commercially sensitive information provided by various parties and cannot be released. The confidential amounts are held by the Ministry of Economic Development and the New Zealand Customs Service.

<sup>2</sup>An alternative duty rate has been set at the NV(VFDE) rate which should be applied instead of the NIFOB rate where the NIFOB amount exceeds the NV(VFDE) amount calculated in NZ dollars due to exchange rate fluctuations.

<sup>3</sup>Other suppliers and exporters not covered by the 2007 Review may lodge a request for a reassessment of the applicable anti-dumping duty, backed by the necessary supporting evidence, for new amounts of anti-dumping duty to be established.

<sup>4</sup>Where the can size is not one of the specified sizes, the rate of duty shall be based on the NIFOB or NV(VFDE) amount for the can size closest to the size of the can imported.

Dated at Wellington this 11th day of February 2008.

HON. LIANNE DALZIEL, Minister of Commerce.

*Note: A non-confidential version of the Reassessment Report, which contains details of the conclusions reached, is available from the Trade Rules and Remedies Group, Competition, Trade and Investment Branch, Ministry of Economic Development, PO Box 1473, Wellington.*

go1026

## Education

### Education Act 1989

#### Notice of Direction to Appoint a Limited Statutory Manager for the Board of Trustees of Brandon Intermediate School (2814)

Pursuant to section 78M of the Education Act 1989, I direct the Secretary for Education to appoint a limited statutory manager for the **Brandon Intermediate School** Board of Trustees because of the risks to the operation of the school and the educational performance of its students.

The following functions, powers and duties of the board are to be vested in a limited statutory manager:

- All functions, powers and duties of the board as an employer (whether statutory or otherwise); and
- all powers and duties of the board to manage strategic planning and school wide self-review (whether statutory or otherwise).

A limited statutory manager must also advise the board on consolidating all new and improved systems into board management practice.

This notice takes effect the day after the date of publication.

Dated at Wellington this 14th day of February 2008.

HON CHRIS CARTER, Minister of Education.

go1076

#### Notice of Direction to Appoint a Limited Statutory Manager for the Board of Trustees of East Otago High School (371)

Pursuant to section 78M of the Education Act 1989, I direct the Secretary for Education to appoint a limited statutory manager for the **East Otago High School** Board of Trustees because of the risks to the operation of the school and the educational performance of the students at the school.

The following functions, powers and duties of the board are to be vested in a limited statutory manager:

- All functions, powers and duties of the board as an employer (whether statutory or otherwise).

A limited statutory manager must also advise the board on the following:

- Consolidating all new and improved systems into board management practice.

This notice takes effect the day after the date of publication.

Dated at Wellington this 14th day of February 2008.

HON CHRIS CARTER, Minister of Education.

go1065

### Private Schools Conditional Integration Act 1975

#### Supplementary Integration Agreement

Pursuant to section 10 of the Private Schools Conditional Integration Act 1975, notice is given that a supplementary integration agreement has been signed between the Minister of Education on behalf of Her Majesty The Queen, acting through the Group Manager, National Operations, Ministry



of Education, pursuant to delegated authority, and the proprietor of the following school:

St Patrick's School, Kaiapoi, Christchurch.

The said supplementary integration agreement was executed on 15 February 2008.

A copy of the supplementary integration agreement is available for inspection without charge by any member of

the public at the regional office of the Ministry of Education, 39 Princess Street, Christchurch.

Dated at Wellington this 15th day of February 2008.

KATHY PHILLIPS, Group Manager, National Operations.

go1174

## Fisheries

### Fisheries Act 1996

#### Fisheries (Seabird Sustainability Measures—Surface Longlines) Notice 2008 (No. F429)

Pursuant to section 11 of the Fisheries Act 1996, the Minister of Fisheries gives the following notice.

#### Notice

1. **Title**—This notice is the Fisheries (Seabird Sustainability Measures—Surface Longlines) Notice 2008.
2. **Commencement**—This notice comes into force the day after the date of its notification in the *New Zealand Gazette*.
3. **Interpretation**—In this notice, unless the context otherwise requires:
  - “Act” means the Fisheries Act 1996;
  - “nautical dawn” means the time at sunrise when the centre of the sun is at a depression angle of 12 degrees below the ideal horizon for the place;
  - “nautical dusk” means the time at sunset when the centre of the sun is at a depression angle of 12 degrees below the ideal horizon for the place;
  - “set”, in relation to a surface longline, means releasing the surface longline into the water;
  - “surface longline” means a line to which a hook or hooks (whether baited or not) are attached, and that is:
    - (a) suspended by floats; and
    - (b) not attached to the sea floor.
4. **Notification of use of surface longlines**—(1) No commercial fisher may use surface longlines to take tuna or swordfish within the exclusive economic zone of New Zealand without giving written notification to the chief executive of the intention to do so at least 5 days before doing so.  
(2) The chief executive may exempt any particular commercial fisher from the requirement of subclause (1) if satisfied in the circumstances that the requirement is not necessary.
5. **Seabird scaring devices required if surface longlines used**—If a commercial fisher uses a surface longline to take fish, aquatic life or seaweed within the exclusive economic zone of New Zealand, the commercial fisher must:
  - (a) carry a seabird scaring device approved by the chief executive on board the vessel used by the commercial fisher; and
  - (b) use the seabird scaring device in accordance with the written requirements issued by the chief executive (if any); and
  - (c) permit inspection of the seabird scaring device on board the vessel used by the commercial fisher at any reasonable time by a fisheries officer or an observer appointed under section 223(2) of the Act.
6. **Restrictions on use of surface longlines**—No commercial fisher may set surface longlines to take fish, aquatic life or seaweed within the exclusive economic zone of New Zealand between the hours of 0.5 hours before nautical dawn and 0.5 hours after nautical dusk, unless line weighting is employed in accordance with clause 7 of this notice.
7. **Line weighting**—(1) For the purposes of clause 6, a metal weight of 45g or more must be attached for every hook deployed.  
(2) The position of the weight must correspond to one of the following:
  - (a) Weights less than 60g must be within 1m of the hook; or
  - (b) weights of 60g–98g must be within 3.5m of the hook; or
  - (c) weights greater than 98g must be within 4m of the hook.
8. **Place of notification**—For the purposes of clause 4(1), a commercial fisher may notify the chief executive by delivering the notification:
  - (a) by hand to Observer Services, Ministry of Fisheries, Level 9, ASB Bank House, 101–103 The Terrace, Wellington; or
  - (b) by post to Observer Services, Ministry of Fisheries, PO Box 1020, Wellington; or
  - (c) by email to [observer@fish.govt.nz](mailto:observer@fish.govt.nz); or
  - (d) by facsimile to (04) 819 4775.
9. **Revocation**—The Fisheries (Seabird Sustainability Measures) Notice 2007 (No. F393) (Supplement to *New Zealand Gazette*, 26 January 2007, No. 8, page 175) is revoked.

Dated at Wellington this 18th day of February 2008.

HON JIM ANDERTON, Minister of Fisheries.

go1185

**Fisheries (Seabird Sustainability Measures—Bottom Longlines) Notice 2008 (No. F430)**

Pursuant to section 11 of the Fisheries Act 1996, the Minister of Fisheries gives the following notice.

**Notice**

1. **Title**—This notice is the Fisheries (Seabird Sustainability Measures—Bottom Longlines) Notice 2008.
2. **Commencement**—This notice comes into force 28 days after the date of its notification in the *New Zealand Gazette*.
3. **Interpretation**—In this notice, unless the context otherwise requires:
  - “Act” means the Fisheries Act 1996;
  - “aerial extent” means the section of the streamer line backbone running from the vessel stern, to where the backbone of the streamer line enters the water;
  - “bottom longline” means a line to which 7 or more hooks (whether baited or not) are attached, and is sunk using weights also attached;
  - “hauling” means the period from when line retrieval commences to when the longline is completely onboard;
  - “nautical dawn” means the time at sunrise when the centre of the sun is at a depression angle of 12 degrees below the ideal horizon for the location of fishing;
  - “nautical dusk” means the time at sunset when the centre of the sun is at a depression angle of 12 degrees below the ideal horizon for the location of fishing;
  - “offal” means solid fish parts, including heads, guts, frames, tails, tentacles and fish trimmings, or parts thereof including minced parts; and
  - “set”, in relation to a bottom longline, means releasing the bottom longline into the water.
4. **Streamer line required**—A commercial fisher using bottom longlines as a method of fishing must:
  - (a) carry a streamer line on board the vessel used by the commercial fisher; and
  - (b) permit inspection of the streamer line at any reasonable time by a fisheries officer or an observer appointed under section 223(2) of the Act.
5. **Use of streamer line during setting of bottom longlines**—During the setting of bottom longlines, the streamer line must be used in accordance with clause 6 of this notice.
6. **Streamer line specifications**—(1) The streamer line must meet the following specifications:
  - (a) The streamer line must be attached to the vessel so that when deployed the baits are protected by the streamer line, even in cross wind;
  - (b) the streamer line must be a minimum of 150 metres in length;
  - (c) the streamer line must achieve a minimum aerial extent of 50 metres;
  - (d) streamers must be brightly coloured;
  - (e) streamers must be spaced at a maximum of 5 metres apart, beginning not more than 5 metres from the stern of the vessel and extending thereafter along the aerial extent of the line;
  - (f) when deployed, each of the streamers must reach the sea surface in the absence of wind and swell. Streamer length will therefore vary depending on the height of their attachment point above the water; and
  - (g) the streamer line must be suspended from a point on the vessel at least 5 metres above the water in the absence of swell.
 (2) The specifications in subclause (1) do not apply to additional or secondary seabird scaring devices fishers may choose to use (such as a second tori or streamer line).
7. **Restrictions on use of bottom longlines**—No commercial fisher may set bottom longlines to take fish, aquatic life or seaweed between the hours of 0.5 hours before nautical dawn and 0.5 hours after nautical dusk, unless line weighting is employed in accordance with clause 8 of this notice.
8. **Line weighting**—(1) For the purposes of clause 7, lines must be:
  - (a) an integrated weighted line with a lead core of at least 50g/m; or
  - (b) when externally weighted gear is used, attach at least 4 kilograms of metal weight for every 60 metres of line.
 (2) Regardless of the type of line weighting used under clause 8(1):
  - (a) any rope or line used to attach weights to the hook-bearing line must not be longer than 10 metres; and
  - (b) no more than 3 floats (up to 120 millimetres in diameter) may be attached to the hook-bearing line for every 60 metres of line, unless an additional 1 kilogram weight is added to the line per additional float; and
  - (c) floats greater than 120 millimetre in diameter are not permitted to the hook bearing line.
9. **Restriction of offal or fish discharge while setting and hauling bottom longlines**—(1) No person may discharge offal or fish during setting of bottom longlines.
 (2) Offal or fish may be discharged during the hauling of bottom longlines provided it is discharged from the side of the vessel that is opposite to side which the hauling station is located.
 (3) Subclause (1) does not apply to:
  - (a) fish that are legally undersize; or
  - (b) fish that are listed on the Sixth Schedule of the Fisheries Act 1996 and that are likely to survive.
10. **The Schedule**—(1) The Schedule provides further guidelines on the design and deployment of streamer lines as seabird scaring devices.
 (2) The Schedule is not part of the specifications.
 (3) If there is any inconsistency between the guidelines in the Schedule and the specifications, the specifications prevail.

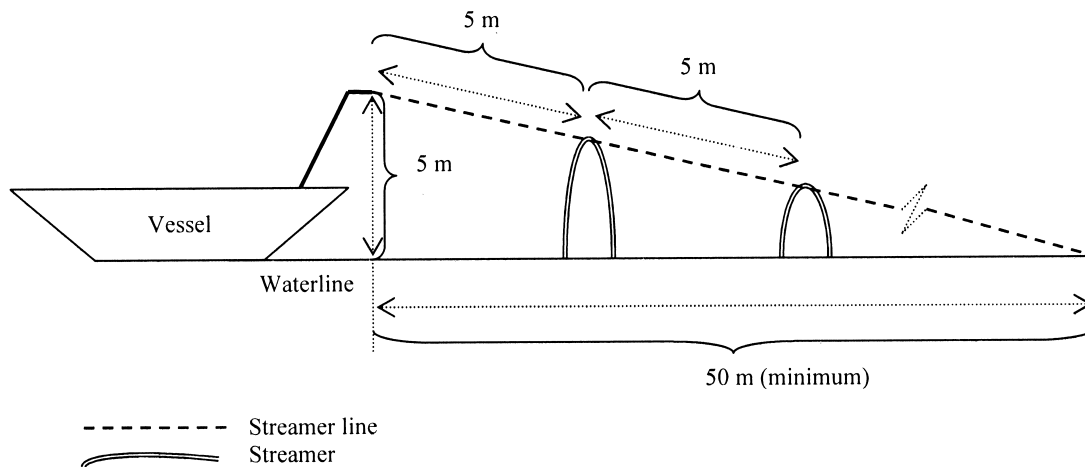
**Seabird Scaring Device (Streamer line)***Diagram not to scale**Not all specifications illustrated*

- (i) The streamer line needs to protect baited hooks from seabirds. This means that the streamer line should be positioned in such a way that streamers are flapping in an unpredictable fashion, above the area in which the baited hooks enter the sea, so that seabirds are deterred from attempting to take bait from the hooks. In order to achieve this even during cross-winds, it is expected fishers will have to make adjustments to the configuration of the streamer line depending on the conditions.
- (ii) It is generally recognised as best practice to maximise the aerial extent of the streamer line, because this maximises the area in which the baited hooks are protected from seabirds. Best practice would be to achieve an aerial extent of 100 metres or more. In order to maximise aerial extent, it is necessary to create tension in the streamer line. This can be achieved by:
  - towing an object on the terminal end of the streamer line; or
  - towing extra length of streamer line; or
  - increasing the diameter of the in-water section of the streamer line.
- (iii) In order to be effective at scaring seabirds away from the line of baited hooks, the streamer lines should not become tangled, either with each other or with the branchline. Each streamer shall be attached to the streamer line in a manner to prevent fouling of individual streamers with the streamer line, and to ensure individual streamers reach the waterline in the absence of wind or swell. Swivels or a similar device can be placed in the streamer line in such a way as to prevent streamers being twisted around the streamer line. Each streamer may also have a swivel or other device at its attachment point to the streamer line to prevent fouling of individual streamers.
- (iv) Streamers are to be spaced at 5-metre intervals along the aerial extent of the line. The total number of streamers in use will vary depending on how the line is configured. Streamers that are hanging in the water can be prone to tangling. Because the far end of the streamer line will frequently be in the water, fishers may not wish to have streamers the whole way down the line. However, it is important that streamers are present to deter birds from taking baited hooks all along the part of the line that remains above water, as outlined in the specifications.
- (v) To ensure streamers are visible to birds, they should stand out against the surroundings. Streamers should be made of brightly coloured fluorescent plastic tubing or other material. Bright colours such as red, yellow, orange or pink are most effective during day setting. For night setting, the streamers should be of a colour that contrasts with the surroundings. Colours such as blue and green are less likely to be effective, because they are less likely to be highly visible to birds.
- (vi) A complete additional streamer line should be carried as a spare.

Dated at Wellington this 18th day of February 2008.

HON JIM ANDERTON, Minister of Fisheries.

go1186

**Fisheries (Seabird Sustainability Measures—Trawl Vessels Less Than 28m) Notice 2008 (No. F431)**

Pursuant to section 11 of the Fisheries Act 1996, the Minister of Fisheries gives the following notice.

**Notice**

1. **Title**—This notice is the Fisheries (Seabird Sustainability Measures—Trawl Vessels Less than 28m) Notice 2008.
2. **Commencement**—This notice shall come into effect on 1 June 2008.
3. **Interpretation**—In this notice:

“hauling” means the period from when the winches are engaged to retrieve the trawl net from fishing depth:

- (a) to when the trawl net is completely onboard; or
- (b) when the trawl net is not brought completely onboard, to when shooting next occurs;

“offal” means solid fish parts, including heads, guts, frames, tails, tentacles and fish trimmings, or parts thereof including minced parts;



“shooting” means the period from when the trawl net is released from the vessel into the water, until the trawl doors and trawl net are fully submerged; and

“tow” means the period after shooting and before hauling, when the trawl net is fully submerged in the water.

**4. Restriction of offal or fish discharge**—(1) No person operating a vessel 28 metres or less in overall length for the purposes of trawling may discharge offal or fish:

- (a) on more than one occasion per tow; or
- (b) during shooting and hauling; or
- (c) within 20 minutes before shooting, unless the vessel has moved at least 1 nautical mile from the location of the last offal or fish discharge.

(2) Subclause (1) does not apply to:

- (a) fish that are legally undersize; or
- (b) fish that are listed on the Sixth Schedule of the Fisheries Act 1996 and that are likely to survive.

**5. Chief executive may grant exemption from discharge restrictions**—(1) The chief executive may, on application by any person, exempt a vessel from the requirement under clause 4, if the chief executive is satisfied that compliance with the requirements under clause 4 would be unsafe for the vessel.

(2) Before granting an exemption, the chief executive may require the person to supply any evidence to show that compliance with the requirements under clause 4 would be unsafe for the vessel.

(3) The chief executive may revoke an exemption granted under subclause (1).

Dated at Wellington this 18th day of February 2008.

HON JIM ANDERTON, Minister of Fisheries.

go1187

### **Fisheries (Seabird Sustainability Measures—Trawl Vessels 28m+) Notice 2008 (No. F432)**

Pursuant to section 11 of the Fisheries Act 1996, the Minister of Fisheries gives the following notice.

#### **Notice**

**1. Title**—This notice is the Fisheries (Seabird Sustainability Measures—Trawl Vessels 28m+) Notice 2008.

**2. Commencement**—This notice shall come into effect on 1 September 2008.

**3. Interpretation**—In this notice:

“hauling” means the period from when the winches are engaged to retrieve the trawl net from fishing depth:

- (a) to when the trawl net is completely onboard; or
- (b) to when shooting next occurs, if the net is not brought completely onboard;

“Limited Processing Fishing Vessel Register” means the register held by the New Zealand Food Safety Authority under the Animal Products (Regulated Control Scheme—Limited Processing Fishing Vessels) Regulations 2001 and called the “Limited Processing Fishing Vessel Register”;

“offal” means solid fish parts, including heads, guts, frames, tails, tentacles and fish trimmings, or parts thereof including minced parts;

“Risk Management Programmes Register” means the register held by the New Zealand Food Safety Authority under the Animal Products Act 1999 and called the “Risk Management Programmes Register”

“shooting” means the period from when the trawl net is released from the vessel into the water, until the trawl doors and trawl net are fully submerged; and

“tow” means the period after shooting and before hauling, when the trawl net is fully submerged in the water.

**4. Restriction of offal or fish discharge**—(1) No person operating a vessel 28 metres or greater in overall length for the purposes of trawling may discharge offal or fish:

- (a) during shooting and hauling; or
- (b) within 20 minutes before shooting, unless the vessel has moved at least 1 nautical mile from the location of the last offal or fish discharge; or
- (c) on more than one occasion per tow, if the vessel is not registered on the Limited Processing Fishing Vessel Register or Risk Management Programmes Register; or
- (d) for a period no longer than 10 minutes at a time, and not again for at least 30 minutes after completion of the previous discharge, if registered on the Limited Processing Fishing Vessel Register or Risk Management Programmes Register.

(2) Subclause (1) does not apply to:

- (a) fish that are legally undersize; or
- (b) fish that are listed on the Sixth Schedule of the Fisheries Act 1996 and that are likely to survive.

**5. Chief executive may grant exemption from discharge restrictions**—(1) The chief executive may, on application by any person, exempt a vessel from the requirement under clause 4, if the chief executive is satisfied that compliance with the requirements under clause 4 would be unsafe for the vessel.

(2) Before granting an exemption, the chief executive may require the person to supply any evidence to show that compliance with the requirements under clause 4 would be unsafe for the vessel.

(3) The chief executive may revoke an exemption granted under subclause (1).

Dated at Wellington this 18th day of February 2008.

HON JIM ANDERTON, Minister of Fisheries.

go1188



---

## Health

---

---

### Medicines Act 1981

---

#### Renewal of Provisional Consent to the Distribution of a New Medicine

Pursuant to section 23 of the Medicines Act 1981, the Minister of Health hereby provisionally consents to the sale, supply or use in New Zealand of the new medicine set out in the Schedule hereto:

##### Schedule

*Product:* **Gutron**  
*Active Ingredient:* Midodrine hydrochloride 2.5mg  
*Dosage Form:* Tablet  
*New Zealand Sponsor:* Douglas Pharmaceuticals Ltd  
*Manufacturer:* Nycomed Austria GmbH, Linz, Austria  
*Note:* This consent is valid for two years from 30 April 2008.

*Product:* **Gutron**  
*Active Ingredient:* Midodrine hydrochloride 5mg  
*Dosage Form:* Tablet  
*New Zealand Sponsor:* Douglas Pharmaceuticals Ltd  
*Manufacturer:* Nycomed Austria GmbH, Linz, Austria  
*Note:* This consent is valid for two years from 30 April 2008.

Dated this 15th day of February 2008.

ANTHONY HILL, Deputy Director-General, Sector Accountability and Funding Directorate (pursuant to delegation given by the Minister of Health on 6 July 2001).

go1206

---

#### Consent to the Distribution of a New Medicine

Pursuant to section 20 of the Medicines Act 1981, the Minister of Health hereby consents to the distribution in New Zealand of the new medicine set out in the Schedule hereto:

##### Schedule

*Product:* **Cetirizine**  
*Active Ingredient:* Cetirizine hydrochloride 10mg  
*Dosage Form:* Film coated tablet  
*New Zealand Sponsor:* REX Medical Ltd  
*Manufacturer:* Cipla Ltd, Manufacturing Division, District Raigad, (Maharashtra), India

Dated this 15th day of February 2008.

ANTHONY HILL, Deputy Director-General, Sector Accountability and Funding Directorate (pursuant to delegation given by the Minister of Health on 6 July 2001).

go1208

---

#### Consent to the Distribution of a Changed Medicine

Pursuant to section 20 of the Medicines Act 1981, the Minister of Health hereby consents to the distribution in New Zealand of the changed medicine which was referred to the Minister of Health under the provisions of section 24(5) of the Act and is set out in the Schedule hereto:

##### Schedule

*Product:* **Ziagen**  
*Active Ingredient:* Abacavir sulfate 351mg equivalent to 300mg abacavir  
*Dosage Form:* Film coated tablet  
*New Zealand Sponsor:* GlaxoSmithKline (NZ) Ltd  
*Manufacturer:* Glaxo Operations UK Limited (t/a Glaxo Wellcome Operations), Ware, Hertfordshire, United Kingdom

Dated this 15th day of February 2008.

ANTHONY HILL, Deputy Director-General, Sector Accountability and Funding Directorate (pursuant to delegation given by the Minister of Health on 6 July 2001).

go1207

## New Zealand Public Health and Disability Act 2000

---

### Reappointments/appointments to the Lower South Regional Ethics Committee

Pursuant to section 11 of the New Zealand Public Health and Disability Act 2000, I reappoint

Kenneth Copland

Gwen Neave

Dr Alan Payne

Associate Professor M. Clare Robertson

as members to the Lower South Regional Ethics Committee for three-year terms of office commencing on the date of this notification; and I also reappoint

Dr George (Philip) White

as a member to the Lower South Regional Ethics Committee for a two-year term of office commencing on the date of this notification.

Dated at Auckland this 30th day of January 2008.

HON DAVID CUNLIFFE, Minister of Health.

go1017

---

### Appointments to the Central Regional Ethics Committee

Pursuant to section 11 of the New Zealand Public Health and Disability Act 2000, I appoint

Dr Nicholas Agar

Dr Dinesh Arya

Carolyn Collins

Dr Diana Martin

Hilary Stace

Dr Mark Weatherall

as members to the Central Regional Ethics Committee for three-year terms of office commencing on the date of this notification; and I also appoint

Helen Colebrook

as chair of the Central Regional Ethics Committee for a two-year term of office commencing on the date of this notification.

Dated at Auckland this 30th day of January 2008.

HON DAVID CUNLIFFE, Minister of Health.

go1018

---

## Inland Revenue

---

### Tax Administration Act 1994

---

#### Notice of Determination Regarding Type of Interest in a Foreign Investment Fund and Use of Fair Dividend Rate Method

1. This is a notice made under section 91AAO(5) of the Tax Administration Act 1994 of a determination made by the Commissioner of Inland Revenue under section 91AAO(1) of that Act.
2. "Determination FDR 2008/01 – use of fair dividend rate method for a type of attributing interest in a foreign investment fund" was signed on 22 January 2008, and

will appear in the Inland Revenue's *Tax Information Bulletin*, Vol. 20, No. 2 of March 2008.

3. The determination is also available from the Inland Revenue website

[www.ird.govt.nz](http://www.ird.govt.nz)

DAVID CARRIGAN, Policy Manager, Policy Advice Division, Inland Revenue.

go1170

---

#### Notice of Determination Regarding Type of Interest in a Foreign Investment Fund and Use of Fair Dividend Rate Method

1. This is a notice made under section 91AAO(5) of the Tax Administration Act 1994 of a determination made by the Commissioner of Inland Revenue under section 91AAO(1) of that Act.
2. "Determination FDR 2008/02 – Fair dividend rate method not to be used for a type of attributing interest in a foreign investment fund" was signed on 8 January 2008, and will appear in the Inland Revenue's *Tax Information Bulletin*, Vol. 20, No. 2 of March 2008.
3. The determination is also available from the Inland Revenue website

[www.ird.govt.nz](http://www.ird.govt.nz)

DAVID CARRIGAN, Policy Manager, Policy Advice Division, Inland Revenue.

go1176

---

## Internal Affairs

---

### Civil Union Act 2004

---

#### Civil Union Celebrants for 2008 Notice No. 3

Pursuant to the provisions of sections 26 and 27 of the Civil Union Act 2004, the following persons have been appointed as civil union celebrants for the period 21 February 2008 to 31 January 2009:

Lowe-Johnson, Pauline Brenda, 562 Cashel Street, Linwood, Christchurch.

Pearson, Nigel Kenneth, 1A Ondine Place, Glenfield, Auckland.

Dated at Wellington this 21st day of February 2008.

B. E. CLARKE, Registrar-General.

go1124

---

### Marriage Act 1955

---

#### Marriage (Approval of Organisations) Notice No. 4

Pursuant to the Marriage Act 1955, the Registrar-General of Marriages hereby gives notice as follows.

##### Notice

1. This notice may be cited as the Marriage (Approval of Organisations) Notice No. 4.
2. The organisation specified in the Schedule hereto is hereby declared to be an approved organisation for the purpose of the Marriage Act 1955.

##### Schedule

Totara Springs Christian Centre.



Dated at Wellington this 21st day of February 2008.

B. E. CLARKE, Registrar-General.

go1129

### Marriage Celebrants for 2008 Notice No. 15

Pursuant to the provisions of section 11 of the Marriage Act 1955, the following name of a marriage celebrant within the meaning of the said Act is published for general information:

Brown, Jacqueline Mary, 104 Harbour View Road, Omokoroa.

Dated at Wellington this 21st day of February 2008.

B. E. CLARKE, Registrar-General.

go1125

### Marriage Celebrants for 2008 Notice No. 16

Pursuant to the provisions of section 8 of the Marriage Act 1955, the following names of marriage celebrants within the meaning of the said Act are published for general information:

Bohlsen, Alwyn Joyce, New Life Churches of New Zealand.

Bradley, Douglas, Presbyterian Church of Aotearoa New Zealand.

Brown, Timothy Hewitt, New Life Churches of New Zealand.

Clark, Glenda, Spiritualist Church of New Zealand.

Comery, Arthur Clayton, Anglican.

Crowther, Beverley Ann, Anglican.

Derouet, Jean-Marie Francois, Apostolic Church.

Hubbard, Grant William, Apostolic Church.

Naera, Marina Edith, Anglican.

Naera, Pitotori, Anglican.

Roussel, David Jack, Elim Church of New Zealand.

Thrupp, John Te Wharetuku, Presbyterian Church of Aotearoa NZ.

Wiki, Rima, Ratana Established Church of New Zealand.

Williams, Martin, Presbyterian Church of Aotearoa NZ.

Dated at Wellington this 21st day of February 2008.

B. E. CLARKE, Registrar-General.

go1126

### Marriage Celebrants for 2008 Notice No. 17

Pursuant to the provisions of section 10 of the Marriage Act 1955, the following names of marriage celebrants within the meaning of the said Act are published for general information:

Ali, Amjad, Islamic Education and Dawah Trust.

Fryett, Joel David, Tauranga Worship Centre.

Garratt, Dale Mary, Covenant Life Church.

Garratt, David Reginald, Covenant Life Church.

Grant, Matthew Lloyd, Grace Church Richmond.

May, Deborah, The Gnostic Society Incorporated.

McAuley, Brian Arthur, Christian City Church – Auckland.

Reddy, Kribendheran, Foursquare Gospel Church of New Zealand.

van Wyngaard, Shaun Conrad, New Apostolic Church.

Walton, Anthony John, The Rock City Church Wellington.

Dated at Wellington this 21st day of February 2008.

B. E. CLARKE, Registrar-General.

go1127

### Marriage Celebrants for 2008 Notice No. 18

Pursuant to the provisions of section 13 of the Marriage Act 1955, it is hereby notified that the following names will be removed from the list of marriage celebrants under sections 8 and 10 of the Act as at 7 March 2008:

Dunn, Paul William, Apostolic Church.

Garratt, Dale Mary, Sanctuary Church.

Garratt, David Reginald, Sanctuary Church.

Glasse, William Boyd, Presbyterian Church of Aotearoa NZ.

Kay, Richard Maurice, Encounter Ministries Trust.

Thrupp, John Wharetuku Tamiana, Presbyterian Church of Aotearoa NZ.

Dated at Wellington this 21st day of February 2008.

B. E. CLARKE, Registrar-General.

go1128

## Justice

### Justices of the Peace Act 1957

#### Justices of the Peace (Retired)

It is noted for information that pursuant to section 3C(2) of the Justices of the Peace Act 1957, I have authorised the following persons to have the designation Justice of the Peace (“J.P.”) (retired):

Andrew Lysaght, of Ashburton.

Ian Kenneth Lankshear, of Tauranga.

Gavin William Ebbett, of Napier.

Lynley Clare Whitton, of Upper Hutt.

Robert Herbert Warburton Hamilton, of Rangiora.

Reginald Ernest Hermans, of Hamilton.

Bartolomeo Moleta, of Nelson.

Brian Hubert Black, of Auckland.

John Walter Robertson, of Whangarei.

Valerie Ormond McKay, of Masterton.

Mary Heather Marunui, of Greytown.

Ngaire Galloway, of Nelson.

Colin Bernard Kruse, of Tauranga.

Johnston Vivian William Thomas, of Christchurch.

Francis William Signal, of Rotorua.

William James Alexander Livsey, of Auckland.

Verdon William Thomas Symanns, of Whangarei.

Colin Timms, of Hamilton.

Neil Walter Spackman, of Auckland.

Raymond William Fleming, of Nelson.

Ian William McMeeking, of Waiuku.

Mary Jane Price, of Christchurch.

Dennis Michael Gillooly, of Collingwood.

Ian Kenneth Lankshear, of Tauranga.

Dated at Wellington this 13th day of February 2008.

BELINDA CLARK, Secretary for Justice.

go1146

#### Justice of the Peace Resignations

It is noted for information that

Loris Elizabeth Mathew, of Te Aroha

Philip John Major, of Hamilton

Ramsay John Gibson, of Darfield  
Alisdair Ian Cameron McKillop, of Christchurch

have resigned their appointments as Justices of the Peace for New Zealand.

Dated at Wellington this 18th day of February 2008.

BELINDA CLARK, Secretary for Justice.

go1164

## Sentencing Act 2002

### Order for Confiscation of Motor Vehicle

Pursuant to sections 128 and 129 of the Sentencing Act 2002, an order was made in the Christchurch District Court on 16 January 2008, for the confiscation of the following motor vehicle:

1994 Ford Fairmont, Registration No. SN1938.

*Against: David Thomas Wilson.*

Anyone who has a legal interest in this vehicle should contact the Court urgently (telephone (03) 962 4131) as the Registrar may sell the vehicle.

This notice is placed pursuant to the Sentencing Regulations 2002.

JACINDA HAMPTON, Deputy Registrar.

go1139

### Order for Confiscation of Motor Vehicle

Pursuant to sections 128 and 129 of the Sentencing Act 2002, an order was made in the Christchurch District Court on 23 January 2008, for the confiscation of the following motor vehicle:

1989 Mitsubishi Galant, Registration No. TB9900.

*Against: Israel Tobias Isaac Phillips.*

Anyone who has a legal interest in this vehicle should contact the Court urgently (telephone (03) 962 4131) as the Registrar may sell the vehicle.

This notice is placed pursuant to the Sentencing Regulations 2002.

JACINDA HAMPTON, Deputy Registrar.

go1138

### Order for Confiscation of Motor Vehicle

Pursuant to sections 128 and 129 of the Sentencing Act 2002, an order was made in the Christchurch District Court on 7 February 2008, for the confiscation of the following motor vehicle:

1984 Ford Telstar, Registration No. LI8813.

*Against: Jade Stephen Cate.*

Anyone who has a legal interest in this vehicle should contact the Court urgently (telephone (03) 962 4131) as the Registrar may sell the vehicle.

This notice is placed pursuant to the Sentencing Regulations 2002.

JACINDA HAMPTON, Deputy Registrar.

go1197

### Orders for Confiscation of Motor Vehicles

Pursuant to sections 128 and 129 of the Sentencing Act 2002, orders were made in the Christchurch District Court on 13 February 2008, for the confiscation of the following motor vehicles:

1982 Honda Civic, Registration No. KM8463.

*Against: Daniel James King.*

1990 Ford Telstar, Registration No. OQ7066.

*Against: Paul Edward Manuel.*

1990 Mitsubishi Galant, Registration No. PE2694.

*Against: Corey Todd Whyte.*

1991 BMW 318i, Registration No. AQQ745.

*Against: Mark Sherwin Stanbury.*

Anyone who has a legal interest in these vehicles should contact the Court urgently (telephone (03) 962 4135) as the Registrar may sell the vehicles.

This notice is placed pursuant to the Sentencing Regulations 2002.

OLIVIA WADSWORTH, Deputy Registrar.

go861

### Order for Confiscation of Motor Vehicle

Pursuant to sections 128 and 129 of the Sentencing Act 2002, an order was made in the Tauranga District Court on 4 February 2008, for the confiscation of the following motor vehicle:

1993 Honda Prelude, Registration No. ZX8292.

*Against: Stephen Andrew Waiti.*

Anyone who has a legal interest in this vehicle should contact the Court urgently (telephone (07) 928 7200) as the Registrar may sell the vehicle.

This notice is placed pursuant to the Sentencing Regulations 2002.

A. GEAR, Deputy Registrar.

go1031

### Order for Confiscation of Motor Vehicle

Pursuant to sections 128 and 129 of the Sentencing Act 2002, an order was made in the Tauranga District Court on 5 February 2008, for the confiscation of the following motor vehicle:

1986 Suzuki motorcycle, Registration No. 69QFN.

*Against: Chase Glen Buckton.*

Anyone who has a legal interest in this vehicle should contact the Court urgently (telephone (07) 928 7200) as the Registrar may sell the vehicle.

This notice is placed pursuant to the Sentencing Regulations 2002.

A. GEAR, Deputy Registrar.

go1030

### Order for Confiscation of Motor Vehicle

Pursuant to sections 128 and 129 of the Sentencing Act 2002, an order was made in the Tauranga District Court on 7 February 2008, for the confiscation of the following motor vehicle:

1996 BMW 318i, Registration No. ECM87.

*Against: Melvin Madhavan.*

Anyone who has a legal interest in this vehicle should contact the Court urgently (telephone (07) 928 7200) as the Registrar may sell the vehicle.

This notice is placed pursuant to the Sentencing Regulations 2002.

F. O'DWYER, Deputy Registrar.

go1015

### Order for Confiscation of Motor Vehicle

Pursuant to sections 128 and 129 of the Sentencing Act 2002, an order was made in the Tauranga District Court on 13 February 2008, for the confiscation of the following motor vehicle:

1993 Mazda Lantis, Registration No. WU2974.

*Against: Michael John O'Keefe.*

Anyone who has a legal interest in this vehicle should contact the Court urgently (telephone (07) 928 7200) as the Registrar may sell the vehicle.

This notice is placed pursuant to the Sentencing Regulations 2002.

F. O'DWYER, Deputy Registrar.

go1061

### Order for Confiscation of Motor Vehicle

Pursuant to sections 128 and 129 of the Sentencing Act 2002, an order was made in the Hawera District Court on 5 February 2008, for the confiscation of the following motor vehicle:

1996 Mitsubishi Galant, Registration No. BCH773.

*Against: Cade Richard Wellington.*

Anyone who has a legal interest in this vehicle should contact the Court urgently (telephone (06) 278 2080) as the Registrar may sell the vehicle.

This notice is placed pursuant to the Sentencing Regulations 2002.

KYLE FINDERUP, Deputy Registrar.

go1092

### Order for Confiscation of Motor Vehicle

Pursuant to sections 128 and 129 of the Sentencing Act 2002, an order was made in the Pukekohe District Court on 11 February 2008, for the confiscation of the following motor vehicle:

1990 Toyota Starlet, Registration No. BEG363.

*Against: Sharyn Marie Kahui.*

Anyone who has a legal interest in this vehicle should contact the Court urgently (telephone (09) 237 0140) as the Registrar may sell the vehicle.

This notice is placed pursuant to the Sentencing Regulations 2002.

JANE HANCOCK, Court Manager.

go1024

### Order for Confiscation of Motor Vehicle

Pursuant to sections 128 and 129 of the Sentencing Act 2002, an order was made in the Pukekohe District Court on 13 February 2008, for the confiscation of the following motor vehicle:

1990 Mitsubishi Delica, Registration No. SG3944.

*Against: Lee Martin De Man.*

Anyone who has a legal interest in this vehicle should contact the Court urgently (telephone (09) 237 0140) as the Registrar may sell the vehicle.

This notice is placed pursuant to the Sentencing Regulations 2002.

JANE HANCOCK, Court Manager.

go1096

### Order for Confiscation of Motor Vehicle

Pursuant to sections 128 and 129 of the Sentencing Act 2002, an order was made in the Hamilton District Court on 23 October 2007, for the confiscation of the following motor vehicle:

1983 Mazda 323, Registration No. LM8519.

*Against: Lance Wiremu Wonnacott.*

Anyone who has a legal interest in this vehicle should contact the Court urgently (telephone (07) 957 7700) as the Registrar may sell the vehicle.

This notice is placed pursuant to the Sentencing Regulations 2002.

A. LEHAN, Deputy Registrar.

go1039

### Order for Confiscation of Motor Vehicle

Pursuant to sections 128 and 129 of the Sentencing Act 2002, an order was made in the Hamilton District Court on 30 October 2007, for the confiscation of the following motor vehicle:

1991 BMW 318i, Registration No. ARA974.

*Against: Laurent Francis Reti.*

Anyone who has a legal interest in this vehicle should contact the Court urgently (telephone (07) 957 7700) as the Registrar may sell the vehicle.

This notice is placed pursuant to the Sentencing Regulations 2002.

DEE HARRISON, Deputy Registrar.

go1006

### Order for Confiscation of Motor Vehicle

Pursuant to sections 128 and 129 of the Sentencing Act 2002, an order was made in the Hamilton District Court on 13 November 2007, for the confiscation of the following motor vehicle:

1990 Holden saloon, Registration No. TC9814.

*Against: Michael George Lewis Muller.*

Anyone who has a legal interest in this vehicle should contact the Court urgently (telephone (07) 957 7700) as the Registrar may sell the vehicle.

This notice is placed pursuant to the Sentencing Regulations 2002.

SIERA PETERU, Deputy Registrar.

go1007

## Social Development

### Social Security Act 1964

#### Extension of Approval for Rural Assistance Under Special Needs Grants Programme

Under clauses 18.2 and 18.6 of the Special Needs Grants Programme, as established and approved on 18 December 1998, under section 124(1)(d) of the Social Security Act 1964 ("the programme"), I extend the approval given on 10 July 2007\* for Part 6 of the programme to apply to specified farmers until the close of 30 June 2008.

Dated this 18th day of December 2007.

RUTH DYSON, Minister for Social Development and Employment.

#### Explanatory Note

*This note is not part of the instrument but is intended to indicate its general effect.*

*This instrument extends, until 30 June 2008, the approval under Part 6 of the Special Needs Grant Programme for rural assistance payments to be made to eligible farmers whose land-based industries in parts of the East Coast, Hawke's Bay and Wairarapa areas, are affected by drought.*

\*New Zealand Gazette, 19 July 2007, No. 82, page 2131

New Zealand Gazette, 28 January 1999, No. 8, page 202

go1196



## The Treasury

### Public Finance Act 1989

#### Notice of Publication of Financial Statements of the Crown

Pursuant to section 31B of the Public Finance Act 1989, the Minister of Finance gives notice of the publication of the financial statements of the Crown for:

- the six months ended 31 December 2007, on 18 February 2008.

Copies of these financial statements are available:

- for inspection free of charge at the National Library of New Zealand, Auckland City Library, Wellington Public Library and Canterbury Public Library;
- for purchase at branches of Bennetts bookshops; and
- through the internet at

<http://www.treasury.govt.nz>

Dated at Wellington this 18th day of February 2008.

HON DR MICHAEL CULLEN, Minister of Finance.

go1141

## Authorities and Other Agencies of State Notices

### Electricity Commission

#### Electricity Governance Regulations 2003

##### Electricity Governance Regulations (Exemption No. 47 (Meridian Energy Limited)) Exemption Notice 2008

Pursuant to Regulation 194(2) of the Electricity Governance Regulations 2003, the Electricity Commission ("Commission") gives the following notice.

#### Notice

**1. Title and commencement**—(1) This notice is the Electricity Governance Regulations (Exemption No. 47 (Meridian Energy Limited)) Exemption Notice 2008.

(2) This notice comes into force on 1 May 2008.

**2. Exemption**—Meridian Energy Limited is exempted from compliance with Rule 3.2 of Part D of the Electricity Governance Rules 2003.

**3. Terms and conditions**—This exemption is granted on the following conditions:

(a) It will only apply to unmetered traffic control signals on the following grid exit points:

- (i) ADD0111;
- (ii) ADD0661;
- (iii) BRY0111;
- (iv) BRY0661;
- (v) ISL0331;
- (vi) ISL0661;
- (vii) PAP0111;
- (viii) PAP0661;
- (ix) SPN0331; and
- (x) KAI0111; and

(b) the exemption will expire on 30 April 2013.

**4. Reasons for granting the exemption**—The reasons for granting this exemption are:

- (a) without an exemption, Meridian will incur significant expenditure and complexity in the fitting of meters to the traffic light point of connections;
- (b) traffic lights are static load and have little variation. Most changes for load are associated with changes in lamp wattage that can be accurately tracked in the distributed unmetered load database;

(c) Meridian has proposed a materially accurate method to calculate consumption for settlement;

(d) the exemption will have little or no impact on other participants and service providers and would not affect any other rules.

Dated at Wellington this 13th day of February 2008.

For and on behalf of the Electricity Commission:

DAVID CAYGILL, Chair.

au1177

##### Electricity Governance Regulations (Exemption No. 48 (Electricity Ashburton Limited and Orion New Zealand Limited)) Exemption Notice 2008

Pursuant to Regulation 194(2) of the Electricity Governance Regulations 2003, the Electricity Commission ("Commission") gives the following notice.

#### Notice

**1. Title and commencement**—(1) This notice is the Electricity Governance Regulations (Exemption No. 48 (Electricity Ashburton Limited and Orion New Zealand Limited)) Exemption Notice 2008.

(2) This notice comes into force on the day after the date it is notified in the *New Zealand Gazette*.

**2. Exemption**—(1) Electricity Ashburton Limited ("EAL") is exempted from compliance with the following Electricity Governance Rules 2003 ("Rules"):

Until 30 April 2008:

- (a) Rule 3.5 of Part D; and
- (b) Rule 4 of Code of Practice G1 of Schedule G8 of Part G;

From 1 May 2008:

- (a) Rule 3.7 of Part D; and
- (b) Rule 19 of Part J.

(2) Orion New Zealand Limited ("Orion") is exempted from compliance with the following Rules:

Until 30 April 2008:

- (a) Rule 5.5.2 of Section VI of Part G;

From 1 May 2008:

- (a) Rule 4.3.2 of Part J.

**3. Terms and conditions**—This exemption is granted on the following conditions:

(a) It shall only apply to:

- (i) the EAL embedded network connected to NSP URK0111; and

(ii) the Orion embedded network connected via EAL embedded network connected to NSP URK0111; and

(b) the exemption will expire on 30 May 2013.

**4. Reasons for granting the exemption**—The reasons for granting this exemption are:

- (a) without an exemption, Orion and EAL would incur significant expenditure and complexity in the fitting of metering and communication equipment to its networks for relatively low consumption volumes;
- (b) the historical nature of the connections and impracticability of connecting strictly in accordance with the Rules;
- (c) EAL and Orion have proposed a materially accurate method to calculate consumption for settlement; and
- (d) there will be little or no impact on other participants and service providers and the proposed exemption would not affect any other rules.

Dated at Wellington this 13th day of February 2008.

For and on behalf of the Electricity Commission:

DAVID CAYGILL, Chair.

au1178

## Environmental Risk Management Authority

### Hazardous Substances and New Organisms Act 1996

#### Determination of New Organisms

Pursuant to section 26 of the Hazardous Substances and New Organisms Act 1996, the Environmental Risk Management Authority hereby determines that:

*Lactobacillus buchneri* (Henneberg 1903) Bergey et al, 1923

*Nitrobacter winogradskyi* Winslow et al, 1917

*Nitrosomonas europaea* Winogradsky, 1892

are **not** new organisms.

Dated at Wellington this 15th day of February 2008.

DR MAX SUCKLING, Chair, Decision-making Committee of the Authority.

au1194

## Land Notices

### Conservation Act 1987

#### Amendment of a Notice—Declaring Land to be Held for Conservation Purposes

Pursuant to section 50A of the Conservation Act 1987, the Community Relations Manager, West Coast Conservancy of the Department of Conservation, hereby amends the notice with the above heading dated the 24th day of January 2008 and published in the *New Zealand Gazette*, 31 January 2008, No. 14, page 359, by omitting from the description of the land in the Schedule of the notice

“SO 396003”

and substituting

“SO 396033”.

Dated at Hokitika this 12th day of February 2008.

CHRIS HICKFORD.

(DOC PAC-11-01-117)

ln1002

### Education Act 1989

#### Land Declared No Longer Required for Education Purposes

Pursuant to section 70A of the Education Act 1989, and pursuant to an authority delegated to me, I, Paul Dickson Burke, Group Manager Property, Ministry of Education, Wellington, hereby give the following notice.

#### Notice

1. The land described in the Schedule to this notice is no longer required for education purposes.
2. This notice shall come into force on 21 February 2008.

#### Schedule

Area ha	Description
0.0607	Lot 18 DP 1842 (all of the land comprised and described in <i>New Zealand Gazette</i> , 28 October 1976, No. 110, page 2448), Westland Land Registration District.

Dated at Wellington this 18th day of February 2008.

P. D. BURKE, Group Manager Property, Ministry of Education.

ln1102

### Land Act 1948

#### Land to be Set Apart for Local Purpose Reserve—Charming Creek, Ngakawau

Pursuant to section 167 of the Land Act 1948, and to a delegation from the Minister for Land Information, Dave Rudge, Land Information New Zealand, declares that an agreement to that effect having been entered into, the land described in the Schedule to this notice is hereby set apart for a local purpose reserve and shall vest in the Department of Conservation on the date of publication of this notice in the *New Zealand Gazette*.

*Nelson Land District—Buller District*

#### Schedule

Area ha	Description
3.9500	Section 1 SO 392314, subject to a right of way over area marked “A” on SO 392314 (created by deed of easement in Computer Interest Register 29433 (SO 305748)).

Dated at Wellington this 13th day of February 2008.

DAVE RUDGE, for the Minister for Land Information.

(LINZ CON/50000/15/16955/00/A-ZNO)

ln1134

## National Parks Act 1980

### Adding Land to Abel Tasman National Park

DAME SIAN ELLIS, Administrator of the Government

#### ORDER IN COUNCIL

At Wellington this 18th day of February 2008

Present:

HER EXCELLENCY THE ADMINISTRATOR OF THE  
GOVERNMENT PRESIDING IN COUNCIL

Pursuant to section 7 of the National Parks Act 1980, Her Excellency the Administrator of the Government, acting on the advice and with the consent of the Executive Council, hereby declares that the land described in the Schedule hereto shall, as from the 28th day after the publication of this Order in Council in the *New Zealand Gazette*, be national park, subject to the National Parks Act 1980, and shall be added to and form part of Abel Tasman National Park.

#### *Nelson Land District—Tasman District*

##### Schedule

Area ha	Description
28.9485	Part Section 5 SO 5328 (all Computer Freehold Register NL11A/230).
28.8855	Sections 1, 2, 3 and 4 SO 14068 (all Computer Freehold Register NL8C/963).
19.6380	Part Section 8 Block V Kaiteriteri Survey District (all <i>New Zealand Gazette</i> , 11 August 1994, No. 81, page 2537).
4.1110	Lot 1 DP 12256 (all Computer Freehold Register NL7B/1062).
3.6160	Lot 10 DP 11641.
1.5243	Section 21 Block VII Takaka Survey District (all <i>New Zealand Gazette</i> , 1 September 1994, No. 89, page 2703).
34.7710	Lot 1 DP 18607 (all Computer Freehold Register NL12B/952).
116.1448	Section 11 Block VI Totaranui Survey District (all Computer Freehold Register NL47/160 – part <i>New Zealand Gazette</i> , 23 November 2006, No. 147, page 4267).
40.0639	Section 1 (Awaroa) Square 10 (all Computer Freehold Register NL49/200 – part <i>New Zealand Gazette</i> , 23 November 2006, No. 147, page 4267).
99.6589	Part Section 2 and part Section 6 Square 10 (all Computer Freehold Register NL65/262 – part <i>New Zealand Gazette</i> , 23 November 2006, No. 147, page 4267).
83.7699	Sections 11 and 14 Square 10 (all Computer Freehold Register NL72/200 – part <i>New Zealand Gazette</i> , 23 November 2006, No. 147, page 4267).
11.8600	Sections 37 and 38 Square 10 (all Computer Freehold Register NL2D/948 – part <i>New Zealand Gazette</i> , 23 November 2006, No. 147, page 4267).
430.5855	Sections 10 and 12 Block VI, Totaranui Survey District (all Computer Freehold Register NL6A/328 – part <i>New Zealand Gazette</i> , 23 November 2006, No. 147, page 4267).
10.8203	Part Section 6 Square 10 (all Computer Freehold Register NL39/111 – part

*New Zealand Gazette*, 23 November 2006, No. 147, page 4267).

DIANE MORCOM, Clerk of the Executive Council.

In965

### Adding Land to Nelson Lakes National Park

DAME SIAN ELIAS, Administrator of the Government

#### ORDER IN COUNCIL

At Wellington this 18th day of February 2008

Present:

HER EXCELLENCY THE ADMINISTRATOR OF THE  
GOVERNMENT PRESIDING IN COUNCIL

Pursuant to section 7 of the National Parks Act 1980, Her Excellency the Administrator of the Government, acting on the advice and with the consent of the Executive Council, hereby declares that the land described in the Schedule hereto shall, as from the 28th day after the publication of this Order in Council in the *New Zealand Gazette*, be national park, subject to the National Parks Act 1980, and shall be added to and form part of Nelson Lakes National Park.

#### *Nelson Land District—Tasman District*

##### Schedule

Area ha	Description
1.9000	Section 1 SO 15542 (all <i>New Zealand Gazette</i> , 13 January 2000, No. 1, page 59 and part <i>New Zealand Gazette</i> , 30 March 2000, No. 30, page 730).
0.2226	Section 1 SO 15607 (part <i>New Zealand Gazette</i> , 13 January 2000, No. 1, page 71).
0.5258	Section 3 SO 15607 (part <i>New Zealand Gazette</i> , 13 January 2000, No. 1, page 71).
0.4047	Section 4 SO 15607 (part <i>New Zealand Gazette</i> , 13 January 2000, No. 1, page 71).
5.5213	Sections 39, 40, 42, 50, 52, 56–63 and part Section 55 Town of St Arnaud (all <i>New Zealand Gazette</i> , 12 December 1991, No. 190, page 3872), SO 7903.

DIANE MORCOM, Clerk of the Executive Council.

In963

### Setting Apart Part of Kahurangi National Park as an Addition to a Specially Protected Area

DAME SIAN ELIAS, Administrator of the Government

#### ORDER IN COUNCIL

At Wellington this 18th day of February 2008

Present:

HER EXCELLENCY THE ADMINISTRATOR OF THE  
GOVERNMENT PRESIDING IN COUNCIL

Pursuant to section 12 of the National Parks Act 1980, Her Excellency the Administrator of the Government, acting on the advice and with the consent of the Executive Council, hereby declares that the land described in the Schedule hereto, shall be set apart as a specially protected area within Kahurangi National Park and shall be included in the Honeycomb Hill Caves Specially Protected Area.

This order shall come into force 28 days after the date of its notification in the *New Zealand Gazette*.

#### *Nelson Land District—Buller District*

##### Schedule

Area ha	Description
38.6800	Part Section 19 SO 15200, situated in Block II Oparara Survey District; marked "A" on



SO 321106 (part Kahurangi National Park by *New Zealand Gazette*, 4 April 1996, No. 33, page 977).

DIANE MORCOM, Clerk of the Executive Council.

In964

## Public Works Act 1981

### Road Stopped and Amalgamated—Te Maire Road, Kaipara District

Pursuant to sections 116 and 117 of the Public Works Act 1981, and to a delegation from the Minister for Land Information, R. J. Sutherland, Land Information New Zealand, declares the portion of road described in the Schedule to this notice to be stopped and, pursuant to section 120(3), amalgamated with the land in Computer Freehold Register NA54D/150, subject to mortgage 6537490.4.

#### North Auckland Land District—Kaipara District Schedule

##### Road Stopped and Amalgamated

Area m <sup>2</sup>	Description
2411	Adjoining or passing through Lot 1 DP 64518 and Allotment 211, Parish of Tatarariki; shown as Section 1 on SO 398020.

Dated at Auckland this 1st day of February 2008.

R. J. SUTHERLAND, for the Minister for Land Information.  
(LINZ CPC/2005/10895)

In1189

### Land Acquired for Road—Beerescourt Road, Hamilton City

Pursuant to section 20(1) of the Public Works Act 1981, and to a delegation from the Minister for Land Information, R. J. Sutherland, Land Information New Zealand, declares that, an agreement to that effect having been entered into, the portion of land described in the Schedule to this notice is hereby acquired for road and shall vest in the Hamilton City Council on the date of publication of this notice in the *New Zealand Gazette*.

#### South Auckland Land District—Hamilton City Schedule

##### Land Acquired for Road

Area m <sup>2</sup>	Description
22	Part Lot 3 DP 34294; shown as Section 1 on SO 387275 (Computer Freehold Register SA887/95).

Dated at Auckland this 18th day of February 2008.

R. J. SUTHERLAND, for the Minister for Land Information.  
(LINZ CPC/2006/11285)

In1193

### Land Declared Road—Arapuni Road, Arapuni Village, South Waikato District

Pursuant to section 114 of the Public Works Act 1981, and to a delegation from the Minister for Land Information, R. J. Sutherland, Land Information New Zealand, declares the land described in the Schedule to this notice to be road vested in the South Waikato District Council excluding mineral interests reserved by section 8 of the Mining Act 1971, section 5 of the Coal Mines Act 1979 and section 11 of the Crown Minerals Act 1991.

### South Auckland Land District—South Waikato District Schedule

Area m <sup>2</sup>	Description
234	Part Lot 81 DP S64364 and part Lot 84 of Section 9 Block XII Maungatautari Survey District; shown as Sections 1 and 2 on SO 398830 (part Computer Freehold Register 127585).

Dated at Auckland this 13th day of February 2008.

R. J. SUTHERLAND, for the Minister for Land Information.  
(LINZ CPC/2008/12625)

In1172

### Land Declared Road—Sargeson Street, Nelson

Pursuant to section 114 of the Public Works Act 1981, and to a delegation from the Minister for Land Information, R. J. Sutherland, Land Information New Zealand, declares the land described in the Schedule to this notice to be road and vested in the Nelson City Council on the date of publication of this notice in the *New Zealand Gazette*.

#### Nelson Land District—Nelson City

##### Schedule

##### Land Declared as Road

Area m <sup>2</sup>	Description
399	Lot 19 DP 17661 (all Computer Freehold Register NL11C/765).

Dated at Auckland this 11th day of February 2008.

R. J. SUTHERLAND, for the Minister for Land Information.  
(LINZ CPC/2005/10901)

In1184

### Land to be Declared Road—State Highway 1, Milburn Straight, Clutha District

Pursuant to section 114 of the Public Works Act 1981, and to a delegation from the Minister for Land Information, R. J. Sutherland, Land Information New Zealand, declares the land described in the Schedule to this notice to be road which, pursuant to section 88(2) of the Transit New Zealand Act 1989, becomes road, limited access road and State highway and shall vest in the Crown on the date of publication of this notice in the *New Zealand Gazette*.

#### Otago Land District—Clutha District

##### Schedule

##### Land to be Declared Road

Area m <sup>2</sup>	Description
1123	Part Section 58 Block VII Tokomairiro Survey District; shown as Section 1 on SO 392397 (part Computer Freehold Register OT37/59).

Dated at Auckland this 11th day of February 2008.

R. J. SUTHERLAND, for the Minister for Land Information.  
(LINZ CPC/2007/12448)

In1202

### Road Realignment—State Highway 1, Mercer–Long Swamp, Meremere, Franklin and Waikato Districts

Pursuant to the Public Works Act 1981, and to a delegation from the Minister for Land Information, Stephen Robert Gilbert, Land Information New Zealand:

(a) Pursuant to section 114, declares the land described in the First Schedule to this notice to be road which,

pursuant to section 88(2) of the Transit New Zealand Act 1989, becomes road, limited access road and State highway and shall vest in the Crown;

(b) Pursuant to section 52, declares the land described in the Second Schedule to this notice is set apart for use in connection with a road (segregation strip) and shall remain vested in the Crown;

(c) Pursuant to section 52, declares the land described in the Third Schedule to this notice is set apart for use in connection with a road (segregation strip) and shall remain vested in the Crown

on the date of publication of this notice in the *New Zealand Gazette*.

**South Auckland Land District—Franklin District Council**

**First Schedule**

*Land Declared Road and State Highway*

Area ha	Description
1.1770	Railway land; shown as Section 38 on SO 383115.
1.7980	Railway land; shown as Section 51 on SO 383115.
0.1013	Railway land; shown as Section 47 on SO 383115.
0.2364	Railway land; shown as Section 54 on SO 383115.
0.0741	Railway land; shown as Section 60 on SO 383115.
0.0818	Railway land; shown as Section 35 on SO 383115.
0.0445	Railway land; shown as Section 49 on SO 383115.

**Second Schedule**

*Land Set Apart for Use in Connection With a Road (Segregation Strip)*

Area ha	Description
0.0007	Railway land; shown as Section 33 on SO 383115.
0.0211	Railway land; shown as Section 36 on SO 383115.
0.0064	Railway land; shown as Section 37 on SO 383115.
0.0098	Railway land; shown as Section 52 on SO 383115.
0.0051	Railway land; shown as Section 53 on SO 383115.
0.0013	Railway land; shown as Section 65 on SO 383115.
0.0004	Railway land; shown as Section 55 on SO 383115.
0.0004	Railway land; shown as Section 34 on SO 383115.
0.0004	Railway land; shown as Section 48 on SO 383115.
0.0004	Railway land; shown as Section 50 on SO 383115.
0.0019	Railway land; shown as Section 61 on SO 383115.

**South Auckland Land District—Waikato District Council  
Third Schedule**

*Land Set Apart for Use in Connection With a Road (Segregation Strip)*

Area ha	Description
0.0026	Railway land; shown as Section 22 on SO 383115.

Dated at Christchurch this 11th day of February 2008.  
S. R. GILBERT, for the Minister for Land Information.  
(LINZ CPC/1998/770)

ln1075

**Road Stopping—Poets Corner Road, Waihi**

Pursuant to sections 116(1), 117(3) and 120(3) of the Public Works Act 1981, and to a delegation from the Minister for Land Information, Stephen Robert Gilbert, Land Information New Zealand, declares the portion of road described in the Schedule to this notice to be stopped and amalgamated with the land in Computer Freehold Register 200682, subject to the encumbrances thereon.

**South Auckland Land District—Hauraki District  
Schedule**

*Road to be Stopped*

Area m <sup>2</sup>	Description
531	Adjoining or passing through Lot 5 DP 348891; shown as Section 1 on SO 395677 (Computer Freehold Register 200682).

Dated at Christchurch this 13th day of February 2008.  
S. R. GILBERT, for the Minister for Land Information.  
(LINZ CPC/2006/11286)

ln1190

**Land Acquired for Public Utility—Sutton Street, Frasertown, Hawke’s Bay**

Pursuant to sections 20 and 50 of the Public Works Act 1981, and to a delegation from the Minister for Land Information, Stephen Robert Gilbert, Land Information New Zealand, declares that, an agreement to that effect having been entered into, the land described in the Schedule to this notice is hereby acquired for a public utility and shall vest in the Wairoa District Council on the date of publication of this notice in the *New Zealand Gazette*.

**Gisborne Land District—Wairoa District  
Schedule**

Area m <sup>2</sup>	Description
505	Lot 2 DP 3790 Block XIII Opoiti Survey District (Gazette Notice 183239.1), Gisborne Registry, subject to Part IVA of the Conservation Act 1987 and section 11 of the Crown Minerals Act 1991.

Dated at Christchurch this 13th day of February 2008.  
S. R. GILBERT, for the Minister for Land Information.  
(LINZ CPC/2007/12404)

ln1140

**Land Declared Road, and Road to be Stopped and Amalgamated—State Highway 43, Ohura Road, Stratford District**

Pursuant to the Public Works Act 1981, and to a delegation from the Minister for Land Information, Stephen Robert Gilbert, Land Information New Zealand:

(a) Pursuant to section 114, declares the land described in the First Schedule to this notice to be road which, pursuant to section 60(2) of the Transit New Zealand Act 1989, shall form part of State Highway 43 and shall vest in the Crown on the date of publication of this notice in the *New Zealand Gazette*.

(b) Pursuant to sections 116 and 117, declares the portion of road described in the Second Schedule to this notice to be stopped and, pursuant to section 120(3), shall be amalgamated with the land in Computer Freehold Register TN208/18, subject to mortgage H394299.8, Part IVA of the Conservation Act 1987 and section 11 of the Crown Minerals Act 1991.

#### **Taranaki Land District—Stratford District**

##### **First Schedule**

###### *Land Declared Road*

Area m <sup>2</sup>	Description
82	Part Section 1 Block VII Pouatu Survey District (part Computer Freehold Register TN208/18); shown as Section 1 on SO 14788.
898	Part Section 1 Block VII Pouatu Survey District (part Computer Freehold Register TN208/18); shown as Section 5 on SO 14788.

##### **Second Schedule**

###### *Road to be Stopped and Amalgamated*

Area m <sup>2</sup>	Description
634	Adjoining or passing through part Section 1 Block VII Pouatu Survey District; shown as Section 7 on SO 14788.

Dated at Christchurch this 12th day of February 2008.

S. R. GILBERT, for the Minister for Land Information.

(LINZ CPC/1998/1329)

In1175

#### **Land Acquired for Sewage Purposes—Near Carter Place, Napier**

Pursuant to section 20(1) of the Public Works Act 1981, and to a delegation from the Minister for Land Information, Stephen Robert Gilbert, Land Information New Zealand, declares that, an agreement to that effect having been entered into, the land described in the Schedule to this notice is hereby acquired for sewage purposes and vested in the Napier City Council on the date of publication of this notice in the *New Zealand Gazette*.

#### **Hawke's Bay Land District—Napier City**

##### **Schedule**

Area ha	Description
0.0144	Part Lot 1 DP 25728; shown as Section 1 on SO 399234 (part Computer Freehold Register 349737).

Dated at Christchurch this 14th day of February 2008.

S. R. GILBERT, for the Minister for Land Information.

(LINZ CPC/2005/10900)

In1145

#### **Road to be Stopped and Amalgamated—Service Lane, Clyde Road/370 Ilam Road, Christchurch City**

Pursuant to sections 116(1), 117(3) and 120(3) of the Public Works Act 1981, and to a delegation from the Minister for Land Information, Stephen Robert Gilbert, Land

Information New Zealand, declares the portion of road described in the Schedule to this notice to be stopped and amalgamated with the land in Computer Freehold Register 9B/1407.

#### **Canterbury Land District—Christchurch City**

##### **Schedule**

Area ha	Description
0.0158	Adjoining Lot 1 DP 20247 and Lots 1, 2, 3 and 5 DP 23933; shown as Section 1 on SO 389669.

Dated at Christchurch this 13th day of February 2008.

S. R. GILBERT, for the Minister for Land Information.

(LINZ CPC/2006/11833)

In1049

#### **Reserves Act 1977**

##### **Classification of Reserve**

Pursuant to the Reserves Act 1977, and to a delegation from Minister of Conservation, the Far North District Council hereby classifies the reserve described in the Schedule hereto as recreation reserve, subject to the provisions of the said Act.

#### **North Auckland Land District—Far North District**

##### **Schedule**

Area ha	Description
3.4029	Part Lot 332 DP 12724.

Dated at Kaikohe this 7th day of February 2008.

CLIVE MANLEY, Chief Executive, Far North District Council.

(File: 1577)

In1118

##### **Classification and Naming of Reserve**

Under the Reserves Act 1977, the Conservation Support Manager for the Northland Conservancy, Department of Conservation, hereby classifies the reserve described in the Schedule as recreation reserve and declares that the reserve be known as the Ocean Beach Recreation Reserve.

#### **North Auckland Land District—Whangarei District**

##### **Schedule**

Area ha	Description
275.6000	Allotment 165 Parish of Manaia, situated in Block I Taranga Survey District and Block II Taiharuru Survey District (all <i>New Zealand Gazette</i> , 6 November 1986, No. 176, page 4683).

Dated at Whangarei this 19th day of February 2008.

H. A. AIKMAN.

(DOC PAR-01-02-31)

In1195

#### **Authorising the Exchange of Part of a Reserve for Other Land—Western Bay of Plenty District**

Under the Reserves Act 1977, the Conservation Support Manager for the Bay of Plenty Conservancy of the Department of Conservation authorises the exchange of that part of the recreation reserve described in the First Schedule for the land described in the Second Schedule.

**South Auckland Land District—Western Bay of Plenty District**

**First Schedule**

Area ha	Description
0.0007	Section 2 SO 398549.

**Second Schedule**

Area ha	Description
0.0007	Section 1 SO 398549.

Dated at Rotorua this 14th day of February 2008.

MARK DAVIES.  
(DOC PAD-04-06)

In1057

**Classification of Seaward Bush Reserve**

Pursuant to the Reserves Act 1977, the Invercargill City Council hereby gives notice that the reserve described in the Schedule hereto is classified as a scenic reserve for the purposes specified in the section 19(1)(b) of the Reserves Act 1977.

**Southland Land District—Invercargill City Council**

**Schedule**

Area ha	Description
107.8933	Lot 1 DP 7967 and Lot 3 DP 359516 (all Computer Freehold Register 242294).

Dated at Invercargill this 7th day of February 2008.

R. W. KING, Chief Executive Officer, Invercargill City Council.

In1012

**Te Ture Whenua Maori Act 1993**

**Setting Apart General Land as a Māori Reservation**

Pursuant to section 338(1) of Te Ture Whenua Maori Act 1993, on the recommendation of the Māori Land Court, that area of general land described in the Schedule hereto is hereby set aside as a Māori reservation for the purpose of a burial reserve to be known as Puke Tapu for the common use and benefit of the descendants of John Masters and Fay Masters (née Reid) and their spouses as well as others with the consent of the trustees may in aroha extend the privilege of being buried there and including descendants of the Reid, Berghan and Windleborne families.

**North Auckland Land District**

**Schedule**

All that piece of land situated in Block IX Takahue Survey District and described as follows:

Area m <sup>2</sup>	Description
120	Part of the land contained as Part Old Land Claim 8 (now Computer Freehold Register NA766/197).

Dated at Wellington this 7th day of February 2008.

LEITH COMER, Chief Executive.

Ministry of Māori Development.

(MLC HO 2/3/1/2; DO Appln A20040004475)

In1182

**Regulation Summary**

**Notice Under the Acts and Regulations Publication Act 1989**

Pursuant to the Acts and Regulations Publication Act 1989, notice is hereby given of the making of Regulations as under:

<i>Authority for Enactment</i>	<i>Title or Subject-matter</i>	<i>Serial Number</i>	<i>Date of Enactment</i>	<i>Retail</i>
Farmers' Mutual Group Act 2007	Farmers' Mutual Group Act 2007 Commencement Order 2008	2008/12	18/2/08	\$1.60
Minimum Wage Act 1983	Minimum Wage Order 2008	2008/13	18/2/08	\$2.10
Electricity Act 1992	Electricity Governance Amendment Regulations 2008	2008/14	18/2/08	\$3.95
Land Transfer Act 1952	Land Transfer Amendment Regulations 2008	2008/15	18/2/08	\$2.30
Immigration Act 1987	Immigration Amendment Regulations 2008	2008/16	18/2/08	\$1.60
Judicature Act 1908	Court of Appeal (Civil) Amendment Rules 2008	2008/17	18/2/08	\$2.30
Aquaculture Reform (Repeals and Transitional Provisions) Act 2004	Aquaculture Reform (Repeals and Transitional Provisions) (Wilson Bay Interim Aquaculture Management Areas) Order 2008	2008/18	18/2/08	\$2.30
Local Government Act 2002 and Remuneration Authority Act 1977	Local Government Elected Members Determination 2008	2008/19	19/2/08	\$5.35
Local Government Act 2002 and Remuneration Authority Act 1977	Local Government Elected Members Determination (No 2) 2007 Amendment Determination 2008	2008/20	19/02/08	\$2.10



**Postage and Packaging Charge: Mail Orders**

If two or more copies are ordered, the remittance should cover the *cash price* and the *maximum charge* for the *total value of purchases* as follows:

<i>Total Value of Purchases</i>	<i>Maximum Charge</i>
\$12.00 and less	\$1.75 p&p
\$12.01 to \$30.00	\$3.50 p&p
\$30.01 and greater	\$5.50 p&p

Copies can be bought or ordered by mail from Legislation Direct, PO Box 12357, Wellington. Please quote title and serial numbers. Prices for quantities supplied on application. Copies are also available over the counter at the following locations:

**Bennetts Bookshop:** Bowen House, Lambton Quay (PO Box 5334), Wellington; **Bennetts Campus Bookshop:** Auckland University of Technology, C Block Wellesley Street, Gate 4 Lorne Street (Private Bag 92006), Auckland; **University of Waikato,** Gate 5 Hillcrest Road (PO Box 13066), Hamilton; **Located in Whitcoulls:** Centreplace, Bryce Street (PO Box 19287), Hamilton; 38–42 Broadway Avenue (PO Box 1820), Palmerston North; 111 Cashel Street (Private Bag), Christchurch; 143 George Street (PO Box 1104), Dunedin.

rs1211

## General Section

### Accounting Standards Review Board

#### Financial Reporting Act 1993

**Approval of the Revised Amendments to New Zealand Equivalent to International Accounting Standard 32 *Financial Instruments: Presentation* and New Zealand Equivalent to International Accounting Standard 1 *Presentation of Financial Statements—Puttable Financial Instruments and Obligations Arising on Liquidation* (Revised Amendments to NZ IAS 32 and NZ IAS 1) (Notice No. 82)**

Notice is hereby given, pursuant to section 29 of the Financial Reporting Act 1993 (“the Act”), that the Accounting Standards Review Board has approved the revised Amendments to New Zealand Equivalent to International Accounting Standard 32 *Financial Instruments: Presentation* and New Zealand Equivalent to International Accounting Standard 1 *Presentation of Financial Statements—Puttable Financial Instruments and Obligations Arising on Liquidation* (revised Amendments to NZ IAS 32 and NZ IAS 1), which has been submitted to it by the Financial Reporting Standards Board of the New Zealand Institute of Chartered Accountants.

The revised Amendments to NZ IAS 32 and NZ IAS 1 are:

- to apply to all reporting entities and groups, the Crown and all departments, offices of Parliament and Crown entities, and all local authorities (each of which is defined in the Act) other than where expressly exempted by its terms, the terms of any other approved financial reporting standard or by law;

- to apply to annual periods beginning on or after 1 January 2009; and
- a Regulation for the purposes of the Regulations (Disallowance) Act 1989.

Earlier application of the revised Amendments to NZ IAS 32 and NZ IAS 1 is permitted only where an entity complies, or has complied, with New Zealand Equivalent to International Financial Reporting Standard 1 *First-time Adoption of New Zealand Equivalents to International Financial Reporting Standards*.

The revised Amendments to NZ IAS 32 and NZ IAS 1 supersede the Amendments to New Zealand Equivalent to International Accounting Standard 32 *Financial Instruments: Presentation* and New Zealand Equivalent to International Accounting Standard 1 *Presentation of Financial Statements—Puttable Financial Instruments and Obligations Arising on Liquidation* (January 2008) (Amendments to NZ IAS 32 and NZ IAS 1 (January 2008)).

The board therefore resolves, pursuant to section 28 of the Act, to revoke its approval of the Amendments to NZ IAS 32 and NZ IAS 1 (January 2008); such revocation is to take effect on the date the revised Amendments to NZ IAS 32 and NZ IAS 1 take effect pursuant to sections 24 and 27 of the Act.

Copies of the revised Amendments to NZ IAS 32 and NZ IAS 1 may be inspected free of charge at, and will be made available for purchase from, the offices of the New Zealand Institute of Chartered Accountants, 40 Mercer Street (PO Box 11342), Wellington.

Dated this 18th day of February 2008.

WARWICK HUNT, Chairman, Accounting Standards Review Board.

gs1199

# Food Standards Australia New Zealand

## Food Standards Australia New Zealand Act 1991

### Australia New Zealand Food Standards Code – Amendment No. 96 – 2008

#### Food Standards Australia New Zealand Act 1991

##### Preamble

The variations set forth in the Schedule below are variations to Standards in the *Australia New Zealand Food Standards Code* published by the National Health and Medical Research Council in the *Commonwealth of Australia Gazette*, No. P 27, on 27 August 1987, which have been varied from time to time.

These variations are published pursuant to section 23A of the *Food Standards Australia New Zealand Act 1991*.

##### Citation

These variations may be collectively known as the *Australia New Zealand Food Standards Code – Amendment No. 96 – 2008*.

##### Commencement

These variations commence on 21 February 2008, with the exception of Item [1.4] which commences on 21 February 2009.

#### SCHEDULE

##### [1] *Standard 1.3.1 is varied by –*

[1.1] *inserting in Schedule 1, under item 8.2 Processed meat, poultry and game products in whole cuts or pieces\* –*

234	Nisin	12.5	mg/kg
-----	-------	------	-------

[1.2] *inserting in Schedule 1, under item 8.3 Processed comminuted meat, poultry and game products\* –*

234	Nisin	12.5	mg/kg
-----	-------	------	-------

[1.3] *inserting in Schedule 1 under item 11.4 Tabletop Sweeteners\* –*

952	Cyclamates	GMP	
-----	------------	-----	--

[1.4] *omitting from Schedule 1, under item 14.1.3 Water based flavoured drinks\* –*

952	Cyclamates	600	mg/kg
-----	------------	-----	-------

*substituting –*

952	Cyclamates	350	mg/kg
-----	------------	-----	-------

##### [2] *Standard 1.3.3 is varied by inserting in the Table to clause 14 –*

Agarose ion exchange resin being agarose cross-linked and alkylated with epichlorohydrin and propylene oxide, then derivatised with tertiary amine groups whereby the amount of epichlorohydrin plus propylene oxide does not exceed 250% by weight of the starting quantity of agarose	Removal of specific proteins and polyphenols from beer	GMP
---	--	-----

##### [3] *Standard 1.3.4 is varied by inserting in the Schedule –*

##### Specification for agarose ion exchange resin

(a) This specification relates to agarose, cross-linked and alkylated with epichlorohydrin and propylene oxide, then derivatised with tertiary amine groups whereby the amount of epichlorohydrin plus propylene oxide does not exceed 250% by weight of the starting quantity of agarose.

(b) The resins are limited to use in aqueous process streams for the removal of proteins and polyphenols from beer. The pH range for the resins shall be no less than 2 and no more than 5, and the temperatures of water and food passing through the resin bed shall not exceed 2°C. pH and temperature restrictions do not apply to cleaning processes.

(c) When subjected to the extraction regime listed in the CFR Title 21 part 173.25(c)(4), but using dilute hydrochloric acid at pH 2 in place of 5% acetic acid, the ion exchange resins shall result in no more than 25 ppm of organic extractives.

## New Zealand Gazette 2008 Deadlines

### Easter Deadlines—21 March 2008 and 24 March 2008

#### *New Zealand Gazette* Edition—27 March 2008

#### Commercial Section Notices: (Companies, Partnership, Insolvency and Land Transfer Acts)

The deadline for these notices will be 12.00 midday on Thursday, 20 March 2008, due to the observance of Good Friday on 21 March 2008 and Easter Monday on 24 March 2008.

All other notices must be lodged at the *New Zealand Gazette* office by 12.00 midday on Tuesday, 25 March 2008.

d2008

## Index

- B**
- Bankruptcy Notices—  
 Bankruptcies: 680  
 No asset procedures: 681
- C**
- Civil Union Act—  
 Lists of civil union celebrants: 716
- Companies Act—  
 Administrations  
 Northern Energy Services Ltd.: 693  
 Cessation of business in New Zealand  
 Austrade Holdings Pty Ltd.: 698  
 IDC Technologies Pty Ltd.: 698  
 Intention to correct Register of Companies  
 AA Insurance Ltd.: 706  
 Absolute CNC Ltd.: 706  
 ACM Insurance Brokers (Hamilton) Ltd.: 706  
 EEC Properties Ltd.: 706  
 Enadnum Ltd.: 706  
 McDonald's Restaurants (New Zealand) Ltd.: 706  
 Messagecom Pty Ltd.: 706  
 NZ Farming Systems Uruguay Ltd.: 706  
 NZFIT Ltd.: 706  
 Pathway Therapeutics Ltd.: 706  
 Patinaform Ltd.: 706  
 Ponoko Ltd.: 706  
 Quayside Holdings Ltd.: 706  
 RVNZ Ltd.: 706  
 Sunridge Estate Ltd.: 706  
 Surrey Trading Ltd.: 706  
 Teviot Irrigation Company Ltd.: 706  
 Waikite Apartments Ltd.: 706  
 Persons prohibited from managing companies: 707
- Removals  
 Albany Cold Storage Ltd.: 695  
 Bader Ltd.: 686  
 Banson & Hegdes Ltd.: 694  
 Belang Developments Ltd.: 695  
 Buckleys Rd Developments Ltd.: 696  
 Cable Linx Systems Ltd.: 694  
 Colmat Beef Ltd.: 696  
 De-Amalfi Survival Ltd.: 694  
 Decorating FX Ltd.: 694  
 Elysian Holdings Ltd.: 696  
 Flyways Travel Ltd.: 694  
 G & M Cocks Ltd.: 697  
 Gleneagles Ltd.: 697  
 Grenada Produce VI Ltd.: 696  
 Hetherington Plasterers Ltd.: 694  
 Huntly Industries Ltd.: 696  
 JJK Holdings Ltd.: 696  
 Kangaloolah Pty Ltd.: 697  
 Main Road Ltd.: 695  
 Major Jones Pool Fishing Lodge Ltd.: 696  
 Ordinum Ltd.: 697  
 Parkway Properties Ltd.: 694  
 Redstock Properties Ltd.: 698  
 Shore Foods Ltd.: 695  
 Silverdale Motors 1999 Ltd.: 694  
 St Aubyns Ltd.: 697  
 Taumata Holdings 2005 Ltd.: 695  
 Thetford Holdings Ltd.: 695  
 Toscanus Ltd.: 697  
 Waitomo Caves Hotel Ltd.: 694  
 Wellesley Hotel Ltd.: 695  
 XChecker Security Ltd.: 695
- Removals lists: 693
- Winding up/liquidations  
 1208979 Ltd.: 682  
 AAA Parts and Auto Services Ltd.: 702  
 Action Business Solutions Ltd.: 701  
 Ahchail Multicultural Ltd.: 704  
 Ambition Wholesalers Ltd.: 689  
 ANZ Teleport & Broadcast Ltd.: 685  
 Appliance Servicing (2004) Ltd.: 692  
 ARL Air Conditioning and Refrigeration Ltd.: 691  
 Armour Roofing Ltd.: 692  
 Art Apartments (2006) Ltd.: 684  
 ART Apartments Ltd.: 684  
 Art Properties Ltd.: 684  
 Artz Hair Ltd.: 682  
 Ashbury Properties Ltd.: 691  
 Aspiro Properties Company Ltd.: 692  
 Auckland Coating Systems Ltd.: 700  
 Auckland Residential Tenancies Ltd.: 684  
 Backspace Ltd.: 689  
 Bader Ltd.: 686  
 Bay Mortgage and Insurance Consultants Ltd.: 703  
 Beazley Bros. Transport Ltd.: 692  
 Becroft Ltd.: 684  
 Black Light Publishing Ltd.: 699  
 Blue Chip Joint Ventures Ltd.: 684  
 Blue Jay Holdings Ltd.: 684  
 Blue Sky Holdings Ltd.: 684  
 Blues Contracting Ltd.: 687  
 Bradshaw Ltd.: 684  
 Bribanc Property Group Ltd.: 684  
 Brown & Taylor Holdings Ltd.: 690  
 C & W Schwass Ltd.: 684  
 Caboose Taupo Ltd.: 692  
 Casino Park Lodge Motel (1997) Ltd.: 682  
 Central Builders Ltd.: 698  
 Central Otago House Ltd.: 700  
 CLC Construction Ltd.: 682  
 Cleary Wealth Management Ltd.: 699  
 Computer Stuff Ltd.: 701  
 Condor Freight Ltd.: 698  
 Coverdale Properties Ltd.: 686  
 D J & P L Zander Ltd.: 689  
 Dave Orrell Builders Ltd.: 682  
 Denby Ltd.: 684  
 Designakit Buildings Ltd.: 700  
 Dream Property Concepts Ltd.: 683  
 Duct Installation & Services Ltd.: 683  
 Duke Street Discounts Ltd.: 683  
 EE Jay Marketers Ltd.: 687  
 Eleworks Consulting Ltd.: 702

Executive Publishing Network NZ Ltd.: 682  
 Express Construction Ltd.: 683  
 Fox & Fox Ltd.: 682  
 Fun Stuff Ltd.: 691  
 GHH Leasing Ltd.: 688  
 Global Strategy Managers Ltd.: 701  
 Gridline Construction Ltd.: 683  
 Gutter Clean Ltd.: 702  
 HFC Ltd.: 683  
 Highclere Developments Ltd.: 704  
 Human Commercials Ltd.: 682  
 Ilminster Ltd.: 684  
 Iridescent Design Ltd.: 682  
 K Road 340 Ltd.: 699  
 Kingsley Ltd.: 684  
 Lanark Ltd.: 684  
 Les Jardins Du Pays Ltd.: 704  
 Lift Tranz Ltd.: 682  
 Lloyd & Stevenson Ltd.: 703  
 Lorraine Adams Design Ltd.: 705  
 LTS Ltd.: 684  
 Mainly Chairs Ltd.: 683  
 Marble Magic Ltd.: 687  
 Margran New Zealand Ltd.: 682  
 Master Butchers Marlborough Ltd.: 682  
 McKeefry Ltd.: 684  
 Medictronix New Zealand Ltd.: 682  
 MHS New Zealand Ltd.: 683  
 Michel's Patisserie NZ Ltd.: 701  
 Minginui Village Council Ltd.: 682  
 Momentum Media Ltd.: 682  
 National Lining Ltd.: 702  
 Ned Kelly Building Supplies (2003) Ltd.: 699  
 New Zealand Protective Coatings Wellington Ltd.: 699  
 Nimbus Holdings Ltd.: 684  
 Nippon Meat Packers New Zealand Ltd.: 688  
 Norm Bengston Ltd.: 691  
 Oceanfront Holdings Ltd.: 682  
 On the Level Builders (06) Ltd.: 705  
 One Broadcast Ltd.: 685  
 Orewa Health Care Center Ltd.: 686  
 Pendale Ltd.: 684  
 Phoenix Linnings Ltd.: 700  
 Photo Enterprises Ltd.: 683  
 Planet Health 2003 Ltd.: 705  
 Point Wines Ltd.: 682  
 Policy Factoring Ltd.: 699  
 Pritam Holdings Ltd.: 685  
 QCG Finance Ltd.: 687  
 Randrup Construction Ltd.: 688  
 Rattray Properties Ltd.: 689  
 Riverpark Ltd.: 689  
 RSM New Zealand Pty Ltd.: 703  
 S M Surfboards Ltd.: 701  
 Sanctuary Developments (Columbia) Ltd.: 689  
 Sanctuary Developments (Portobello Terraces) Ltd.: 690  
 Sandra and Nick Ltd.: 685  
 Scorpix Ventures Ltd.: 682  
 Sheppard Sawmills Ltd.: 698  
 Smartzone Co NZ Ltd.: 702  
 Solidpi Holdings Ltd.: 704  
 Southwark Street Investments Ltd.: 688  
 Speight Enterprises Ltd.: 685  
 SS Service Centre Ltd.: 683  
 Stewart Island Investments Ltd.: 687  
 Strand Fisk & Muldoon Ltd.: 686  
 Strowan Ltd.: 684  
 Suite Centre Ltd.: 705  
 Sure Construction Ltd.: 692  
 Sure Electrical Ltd.: 692  
 T & J Te Huna Contracting Ltd.: 688  
 T Edgcombe Horticulture Ltd.: 701  
 T.B.W. Holdings Ltd.: 690  
 Tanner Properties Ltd.: 703  
 Tasman Cleaning Ltd.: 703  
 Tawari Street Trustee Ltd.: 682  
 Te Korowai o Te Arohanoa Inc.: 704  
 The Apparel Index Ltd.: 700  
 The Landings Management Services Ltd.: 684  
 Token Investments Ltd.: 686  
 Tri Produce (1999) Ltd.: 690  
 Tri Produce Company Ltd.: 690  
 Wakatipu Naturally Ltd.: 704  
 Wanaka Gas Ltd.: 705  
 Win-Dey Construction Ltd.: 700  
 Wingsfield Ltd.: 683

Conservation Act—  
 Land notices  
 Westland  
 Amendment 2008/359: 721  
 Crown Entities Act—  
 Appointments/reappointments  
 New Zealand Trade and Enterprise Board: 709  
 Crown Solicitors Regulations—  
 Appointments  
 Crown Solicitors: 709

**D**

Dumping and Countervailing Duties Act—  
 Reassessment of anti-dumping duty  
 Canned peaches from South Africa: 709

**E**

Education Act—  
 Direction for appointment of limited statutory managers  
 Brandon Intermediate School: 710  
 East Otago High School: 710  
 Land no longer required for education purposes: 721  
 Electricity Governance Regulations—  
 Exemptions  
 Electricity Ashburton Ltd.: 720  
 Meridian Energy Ltd.: 720  
 Orion New Zealand Ltd.: 720

**F**

Financial Reporting Act—  
 Approvals  
 Amendments  
 Revised New Zealand Equivalent to International Accounting  
 Standard 1: 727  
 Revised New Zealand Equivalent to International Accounting  
 Standard 32: 727

**Fisheries Act—**

Fisheries notices  
 Seabird sustainability measures  
 Bottom longlines: 712  
 Surface longlines: Revocation 2007/175: 711  
 Trawl vessels 28m+: 714  
 Trawl vessels less than 28m: 713

**Food Standards Australia New Zealand Act—**

Variations to the Australia New Zealand Food Standards Code  
 Amendment No. 96: 728

**H**

Hazardous Substances and New Organisms Act—  
 Determination of new organisms: 721

**I**

Insolvency Act—  
 Adjudication annulments: 681  
 Insurance Companies' Deposits Act—  
 Proposed release of deposits  
 Alliance Australia Claim Services Ltd.: 708

**J**

Justices of the Peace Act—  
 Resignations: 717  
 Retirements: 717

**L**

Land Act—  
 Land notices  
 Buller: 721  
 Land Notices—  
 Other Cities  
 Napier: 725  
 Other Districts  
 Wairoa: 724  
 Roading Cities  
 Christchurch: 725  
 Hamilton: 723  
 Nelson: 723  
 Roading Districts  
 Clutha: 723  
 Franklin: 723  
 Hauraki: 724  
 Kaipara: 723



South Waikato: 723  
 Stratford: 724  
 Waikato: 723  
 Land Transfer Act—  
 Land Registrar notices  
 Christchurch: 707

**M**

Maori Land Act (Te Ture Whenua Maori Act)—  
 Land notices  
 North Auckland: 726  
 Marriage Act—  
 Approval of organisations: 716  
 Lists of marriage celebrants: 717  
 Marriage celebrants removed from list: 717  
 Medicines Act—  
 Consent to the distribution of changed medicines: 715  
 Consent to the distribution of new medicines: 715  
 Renewal of provisional consent to the distribution of new medicines:  
 715

**N**

National Parks Act—  
 Land notices  
 Buller: 722  
 Tasman: 722  
 New Zealand Public Health and Disability Act—  
 Appointments/reappointments  
 Central Regional Ethics Committee: 716  
 Lower South Regional Ethics Committee: 716

**P**

Partnership Act—  
 Special partnership certifications  
 KAF Services Limited and Co.: 706  
 Private Schools Conditional Integration Act—  
 Supplementary integration agreements: 710  
 Property Law Act—  
 Entry into possession of mortgaged property: 708  
 Public Finance Act—  
 Publication of financial statements of the Crown: 720  
 Public Trust Act—  
 Unclaimed property: 708

**R**

Receiverships Act—  
 Appointment and release of receivers and managers  
 Cowperthwaite Ltd.: 681  
 International Environmental Engineering Ltd.: 681  
 Regulations (Acts and Regulations Publication Act)—  
 Aquaculture Reform (Repeals and Transitional Provisions) (Wilson  
 Bay Interim Aquaculture Management Areas) Order 2008  
 (SR 2008/18): 726  
 Court of Appeal (Civil) Amendment Rules 2008 (SR 2008/17): 726  
 Electricity Governance Amendment Regulations 2008 (SR 2008/14):  
 726  
 Farmers' Mutual Group Act 2007 Commencement Order 2008  
 (SR 2008/12): 726  
 Immigration Amendment Regulations 2008 (SR 2008/16): 726  
 Land Transfer Amendment Regulations 2008 (SR 2008/15): 726  
 Local Government Elected Members Determination (No 2) 2007  
 Amendment Determination 2008 (SR 2008/20): 726  
 Local Government Elected Members Determination 2008  
 (SR 2008/19): 726  
 Minimum Wage Order 2008 (SR 2008/13): 726  
 Reserves Act—  
 Land notices  
 Far North: 725  
 Invercargill: 726  
 Western Bay of Plenty: 725  
 Whangarei: 725

**S**

Sentencing Act—  
 Confiscation of motor vehicles: 718, 719  
 Social Security Act—  
 Programmes  
 Special Needs Grants (rural assistance approval)  
 Extension 1999/202, 2007/2131: 719

**T**

Tax Administration Act—  
 Determinations: 716